

DIRC project: overview and status

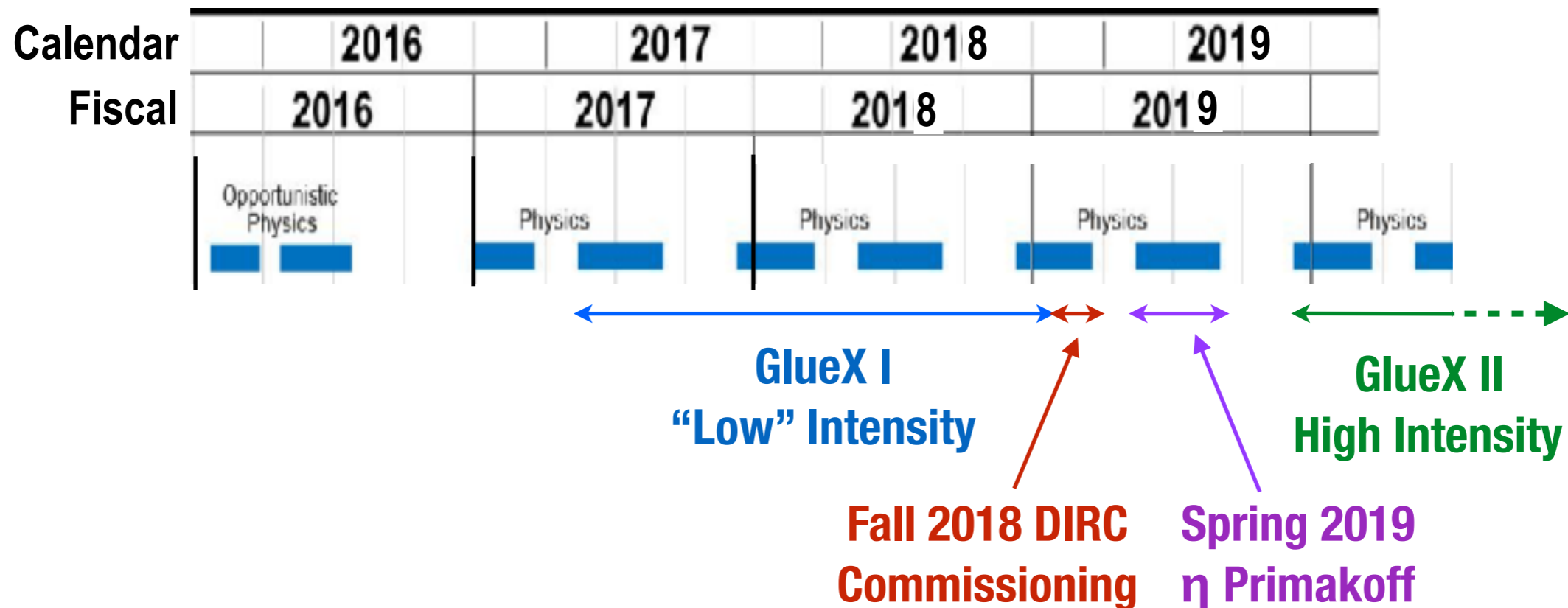

GlueX DIRC Working Group
June 25, 2018

Hall D beam schedule



- * Low intensity (GlueX I) will be completed by end of October 2018
- * This readiness review aims to address:
 - * Initial DIRC commissioning in Fall 2018 (3 weeks of beam)
 - * High Intensity GlueX II in Fall 2019 including the DIRC

DIRC project organization

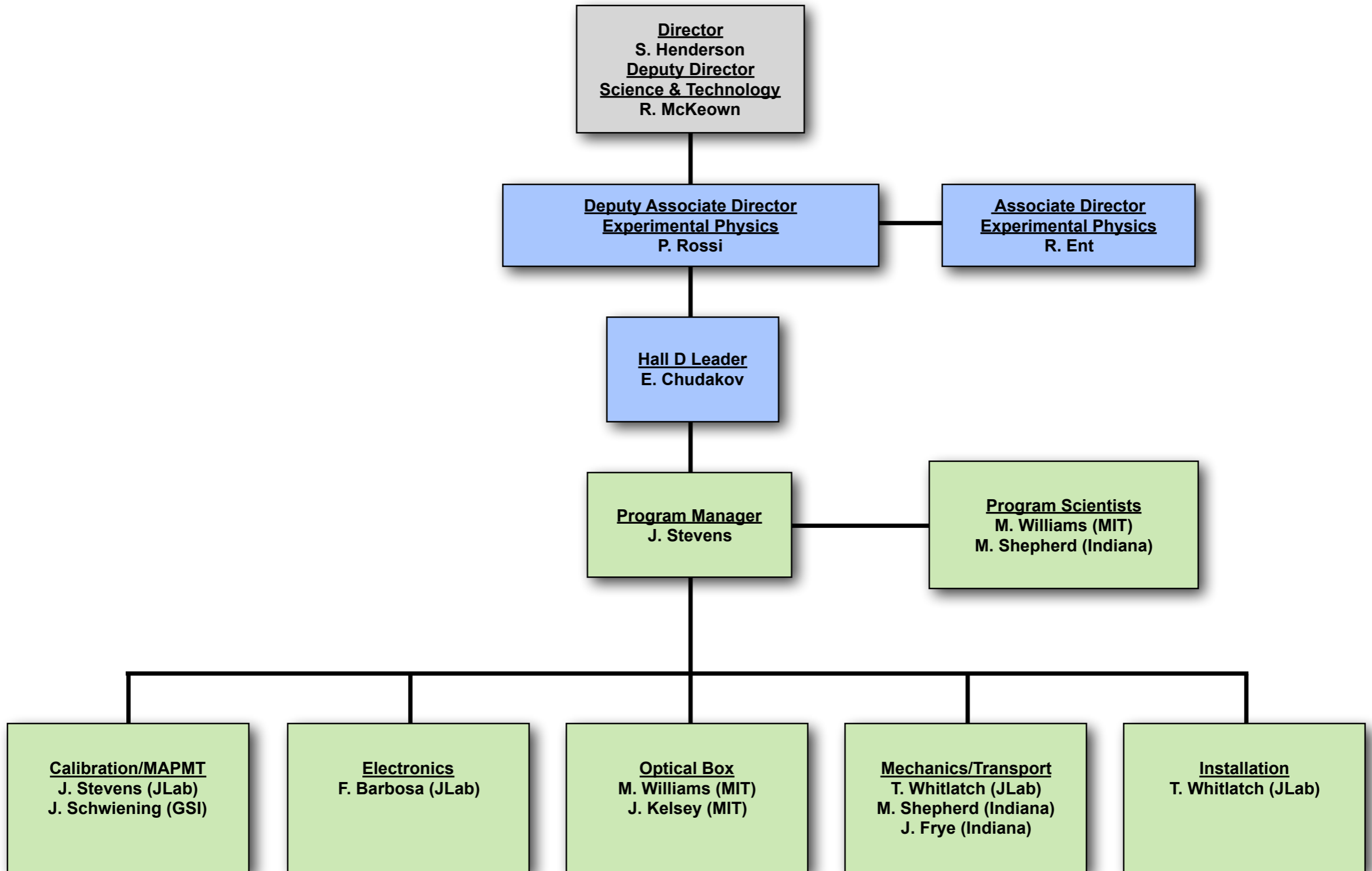

Particle Identification: DIRC

- * **DIRC:** Detection of Internally Reflected Cherenkov Light
- * Pioneered for BaBar detector at SLAC PEP-II
- * Image photons to measure Cherenkov angle

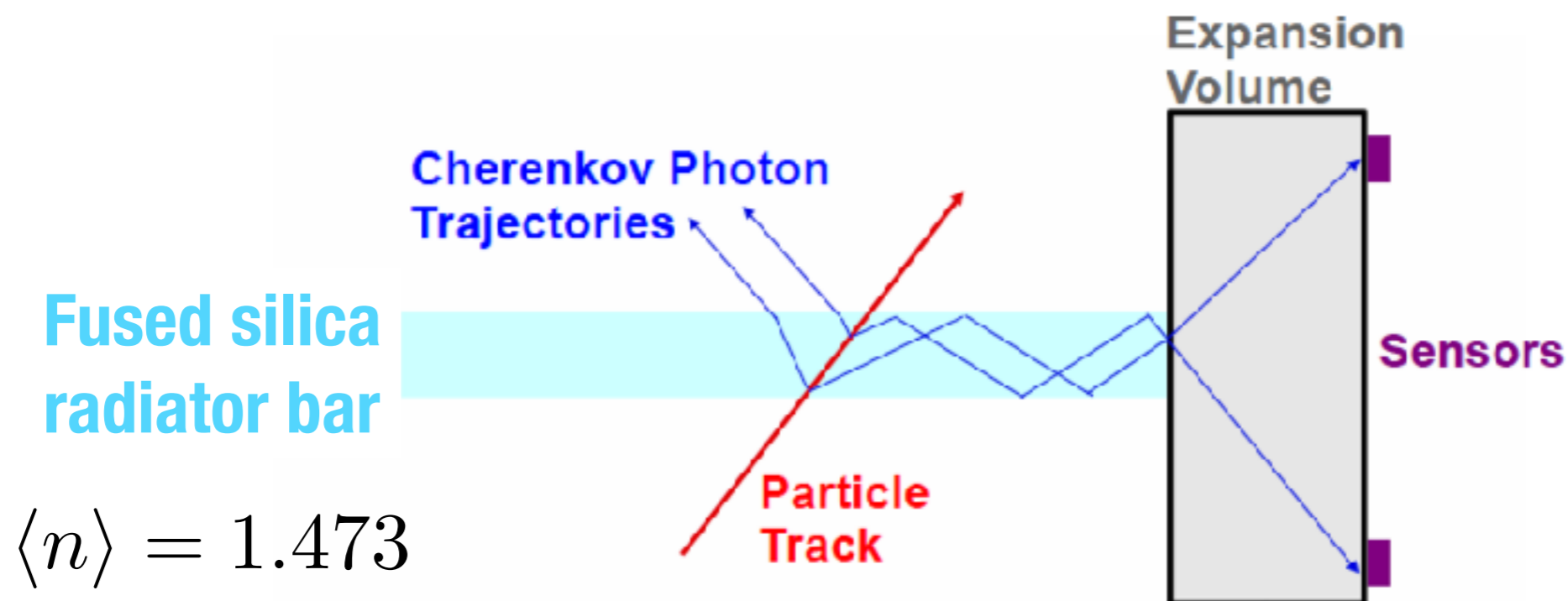
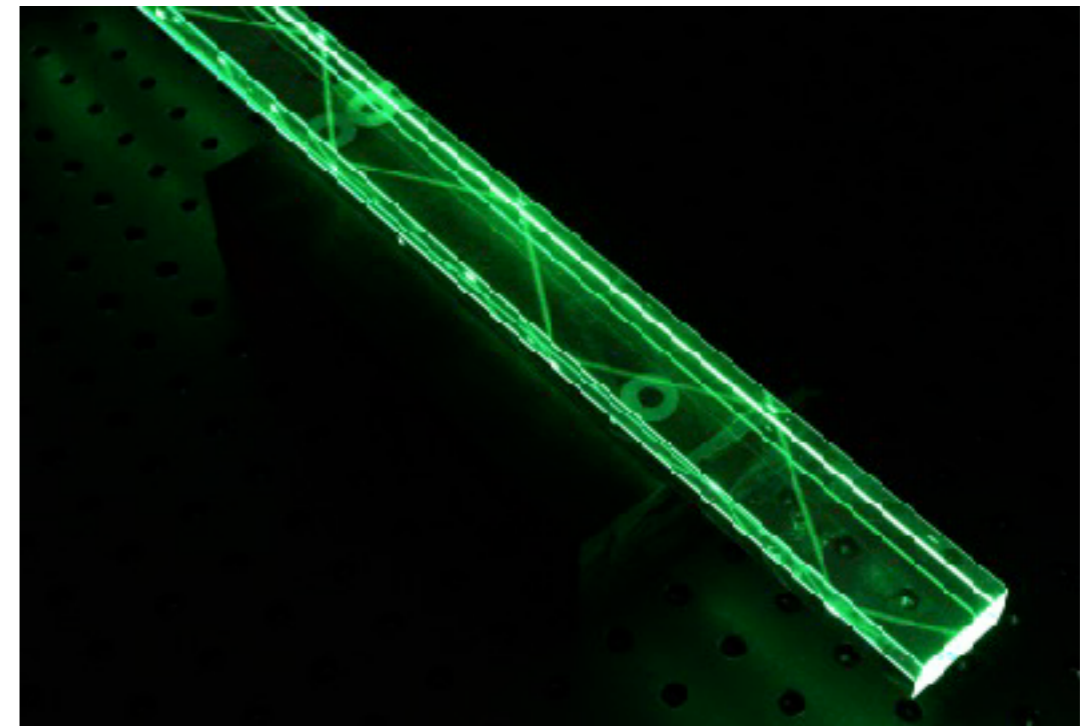

GLUEX DIRC

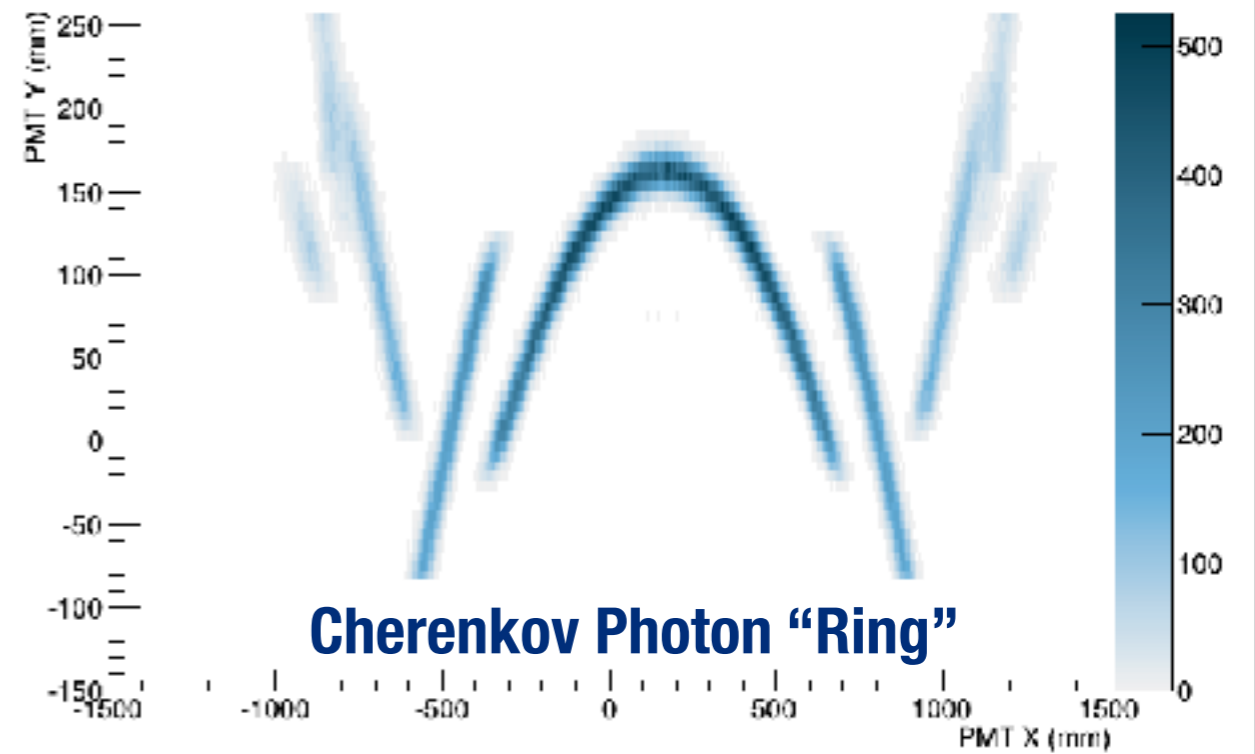
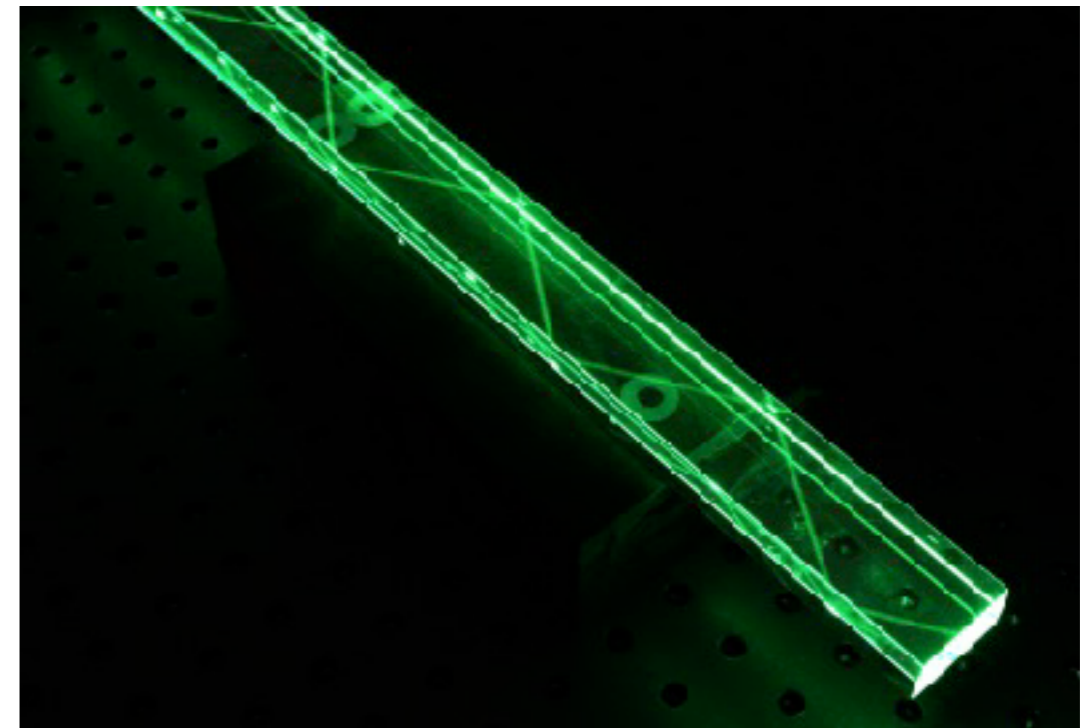
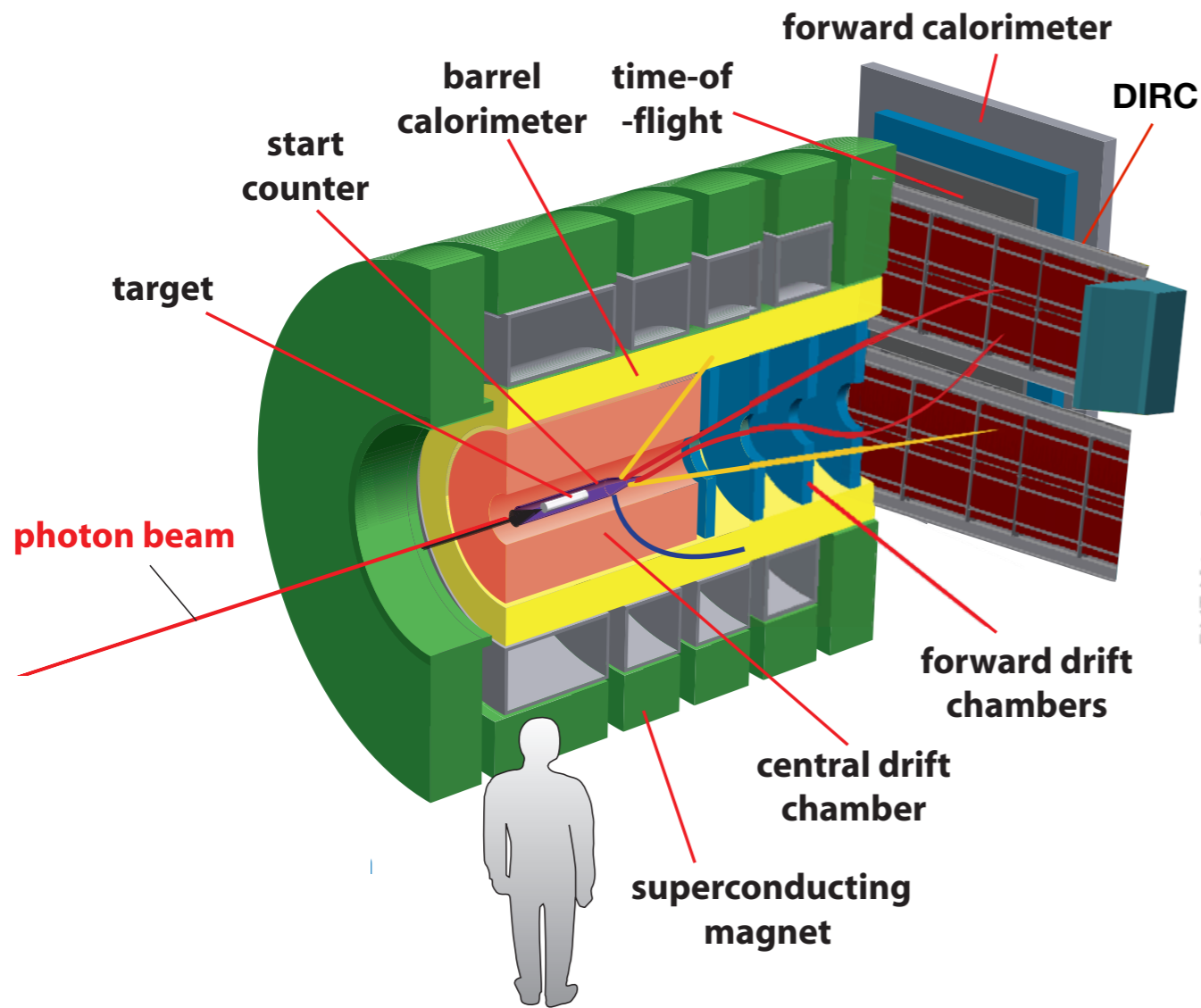

DIRC detector overview

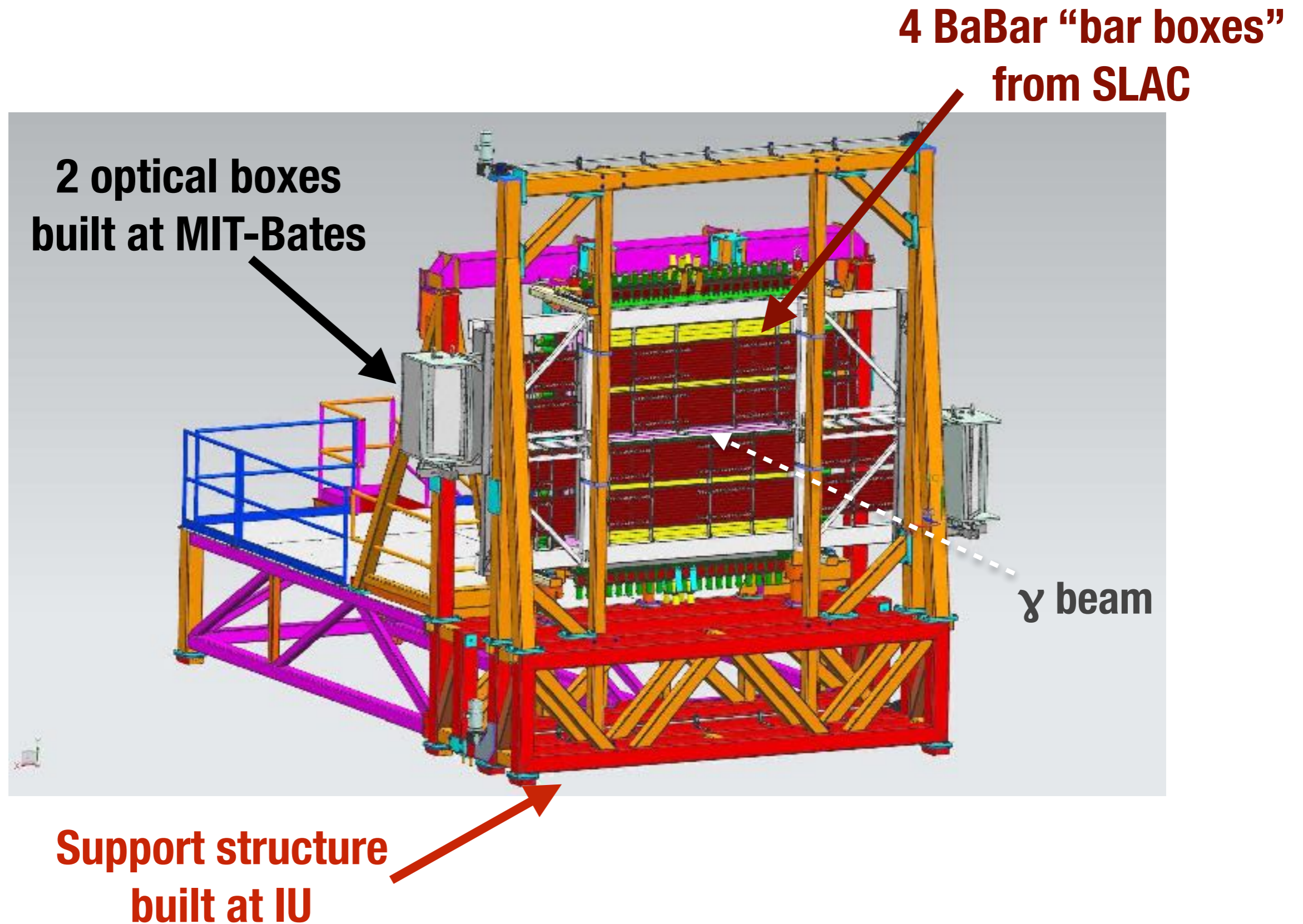

Mechanics: Support structure



INDIANA UNIVERSITY



Support structure

- * Follow similar structure for supporting bar boxes from BaBar
- * **Requirements:**
 - * Minimized material in active area in front of FCAL calorimeter
 - * Ability to remove detector elements from active area for other experiments, eg. PrimeX
- * Delivered in July 2017 and **installation completed!**

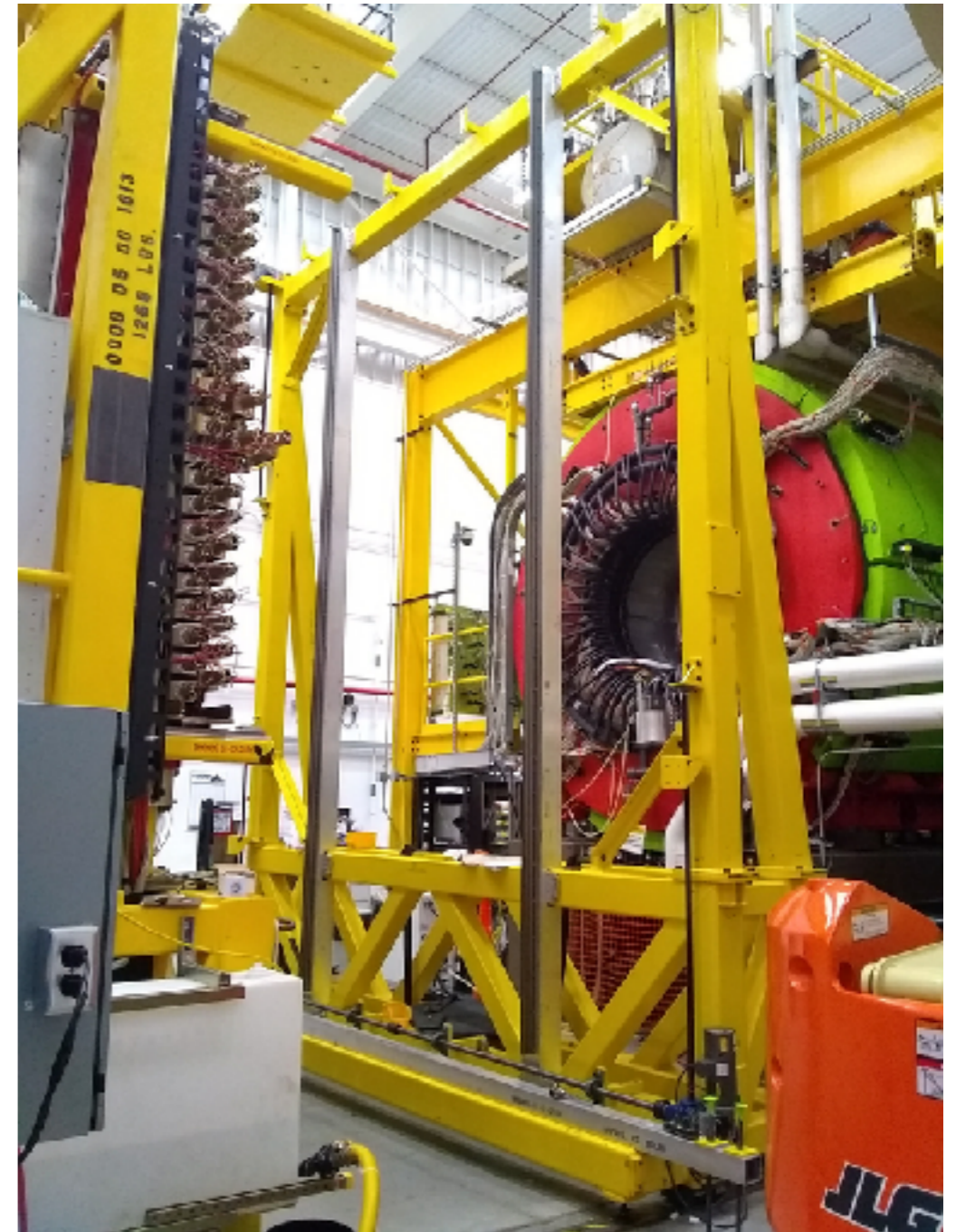

Hall D installation views

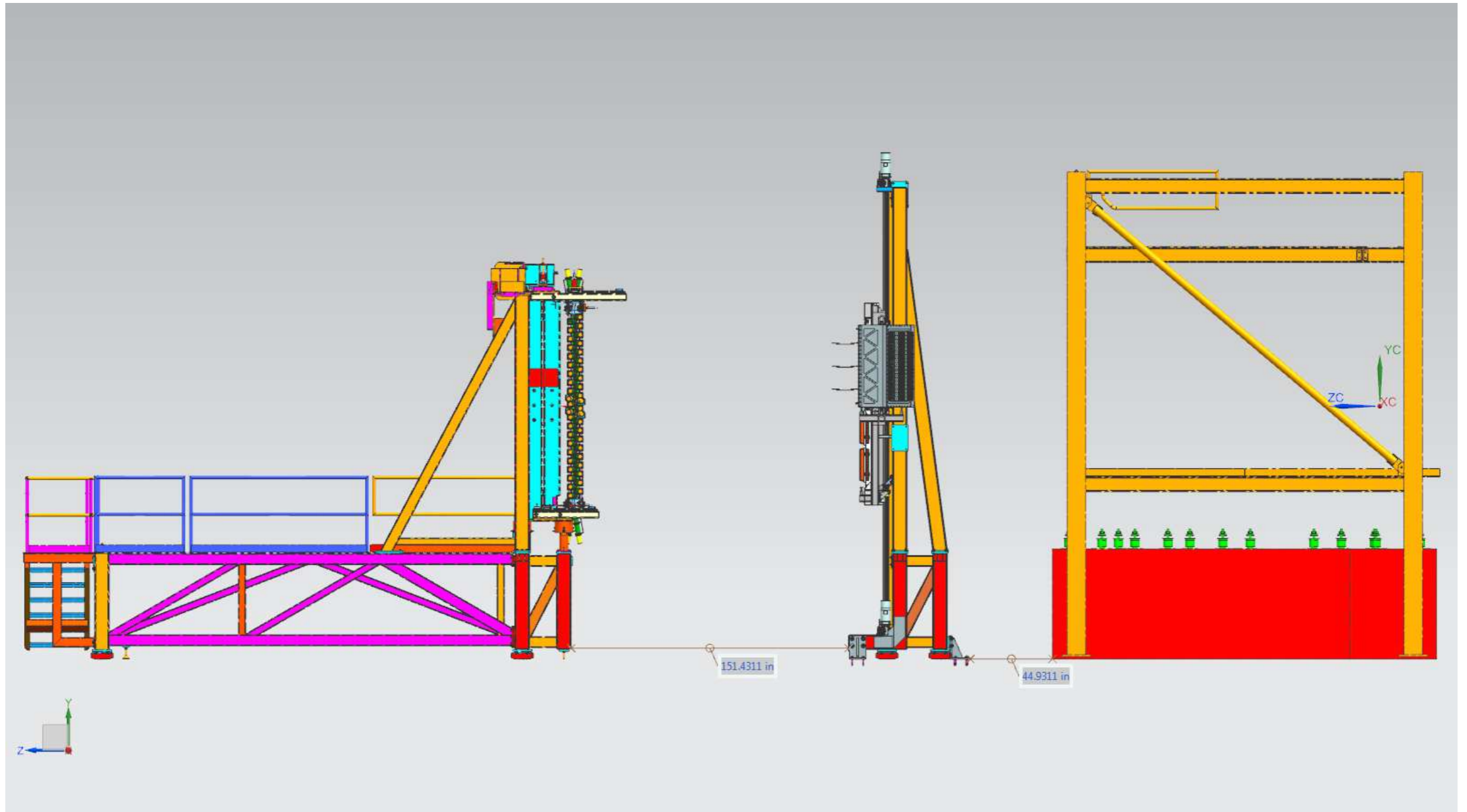

Hall D installation views

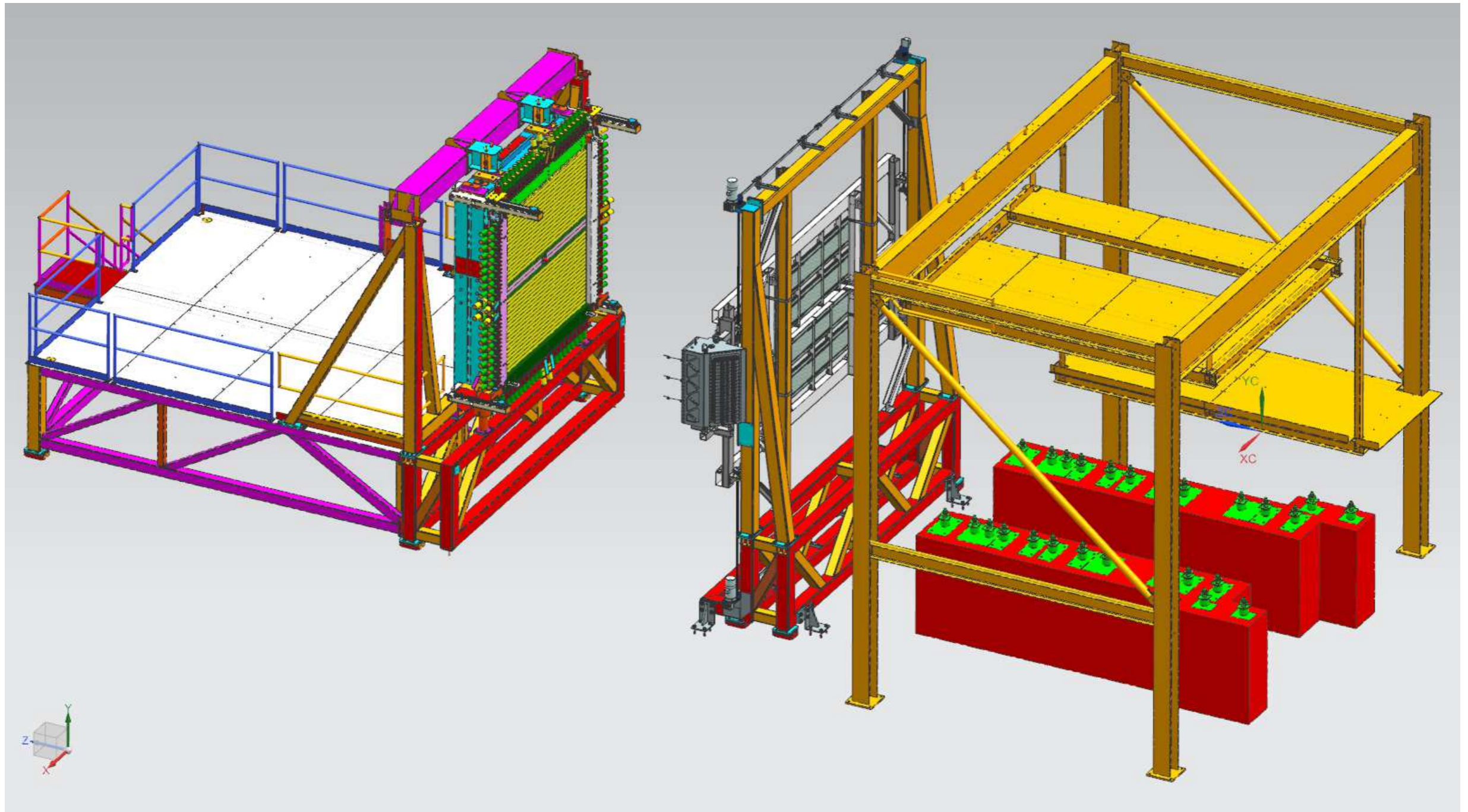

Hall D installation views

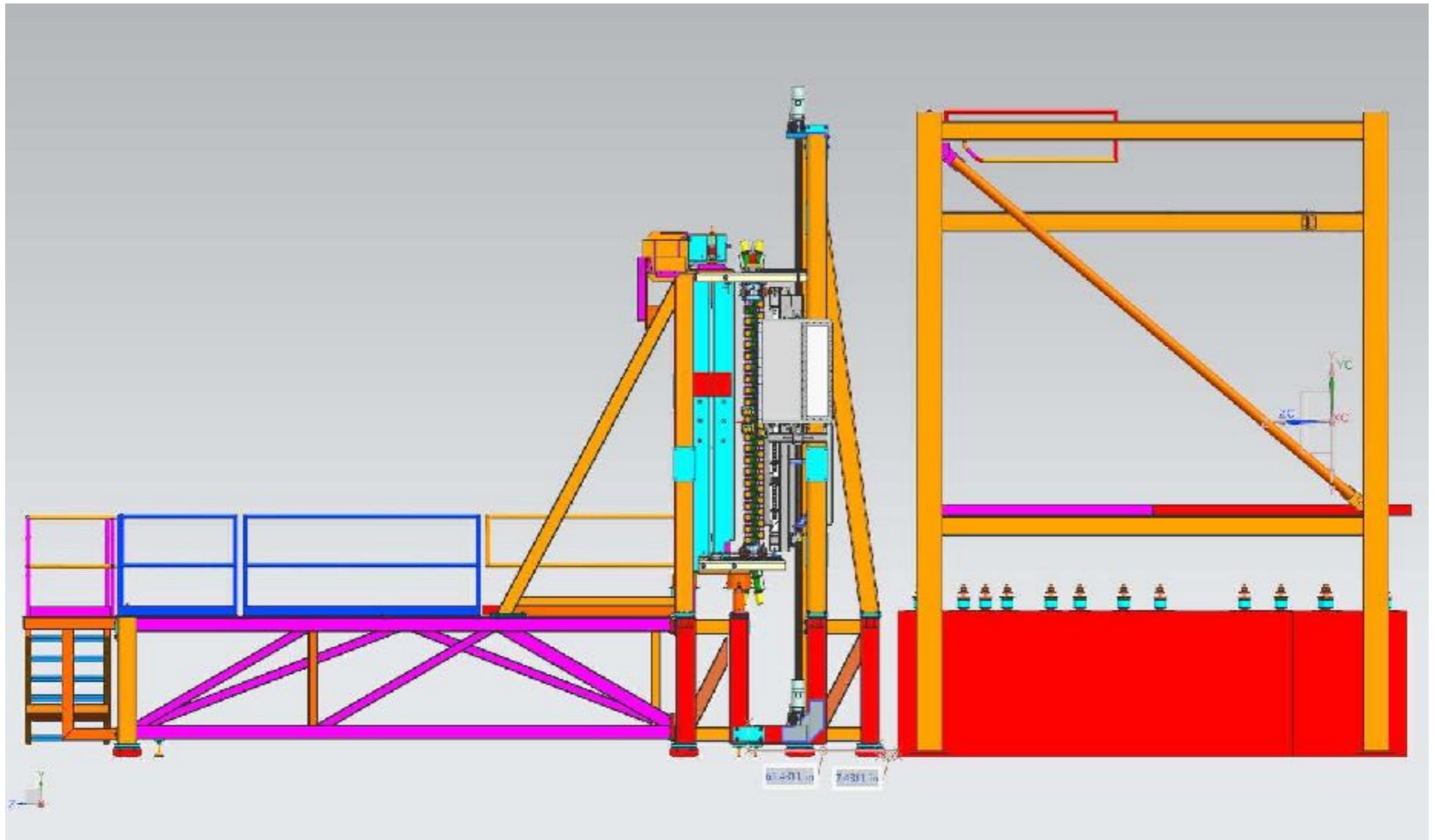

Transportation





Final shipment from SLAC 3 weeks ago!

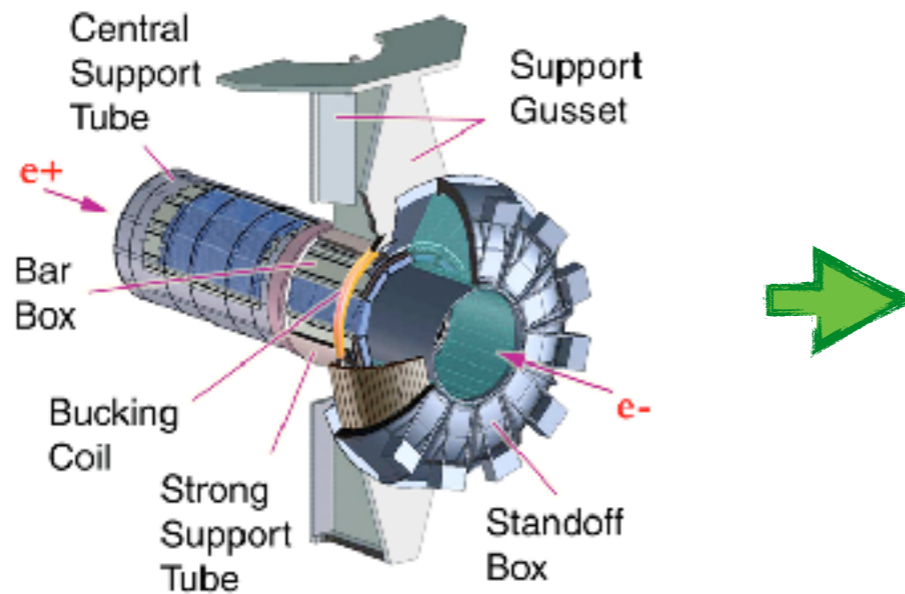

Follow the trip:  @GlueX_DIRC

Transportation strategy

- * Transport 4 bar boxes from SLAC to JLab in two separate shipments
- * First bar box shipment in November 2017, second shipment of three after demonstrating initial trip
- * System required to monitor bar boxes in transit
 - * Camera system developed and extensively tested with boxes at SLAC before transport
 - * Full system developed (cameras, N₂ sensors, accelerometers, etc.) for real time monitoring
 - * Central computer on truck broadcasts wireless to trail car, over the entire trip

Transportation **complete!**

- ✱ 4 bar boxes transported from SLAC to JLab with no visible issues mechanically or optically
- ✱ 2 bar boxes successfully installed for Fall 2018 commissioning; remaining 2 stored safely in Hall D
- ✱ Planning to write document on procedure for future possible shipments (*not in GlueX project scope*)

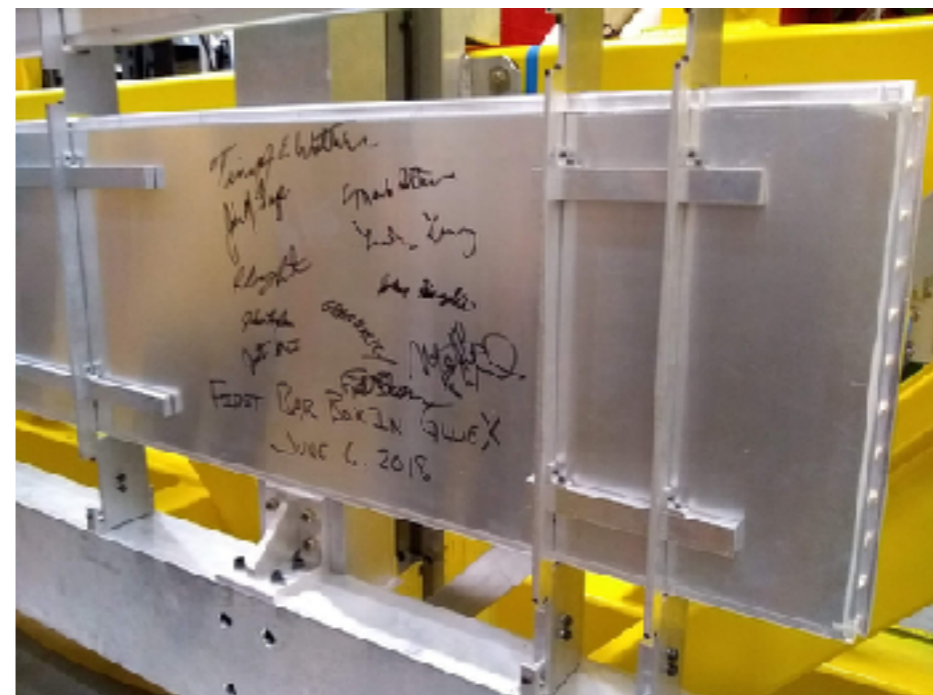

Optical box: design and fabrication



Optical box design

Design from 2015 review

- ✳ Improved coupling of bar box and optical box
- ✳ Calibration light sources added
- ✳ Optical cookies for PMT coupling
- ✳ Thicker quartz window required

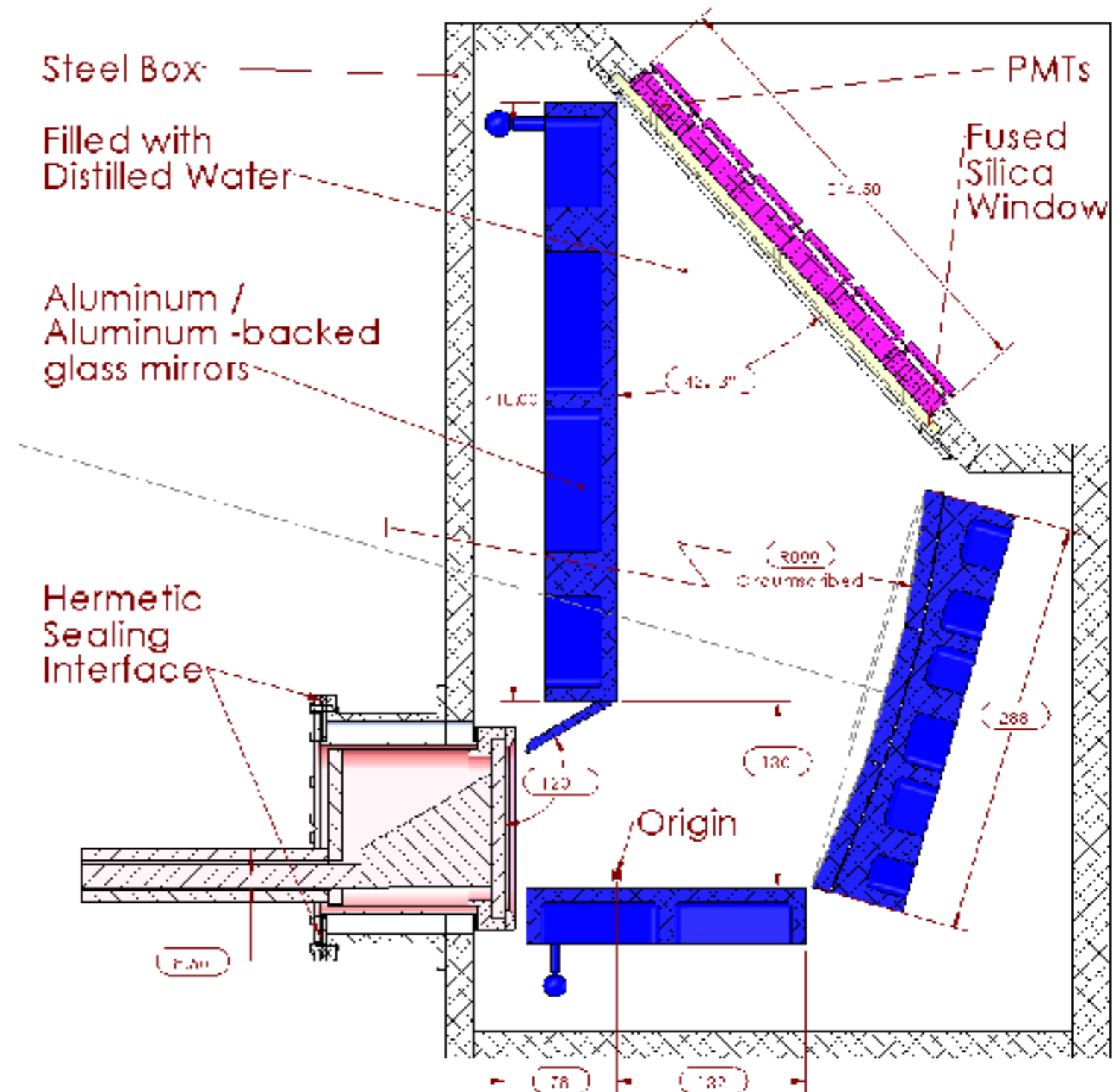

Optical box design

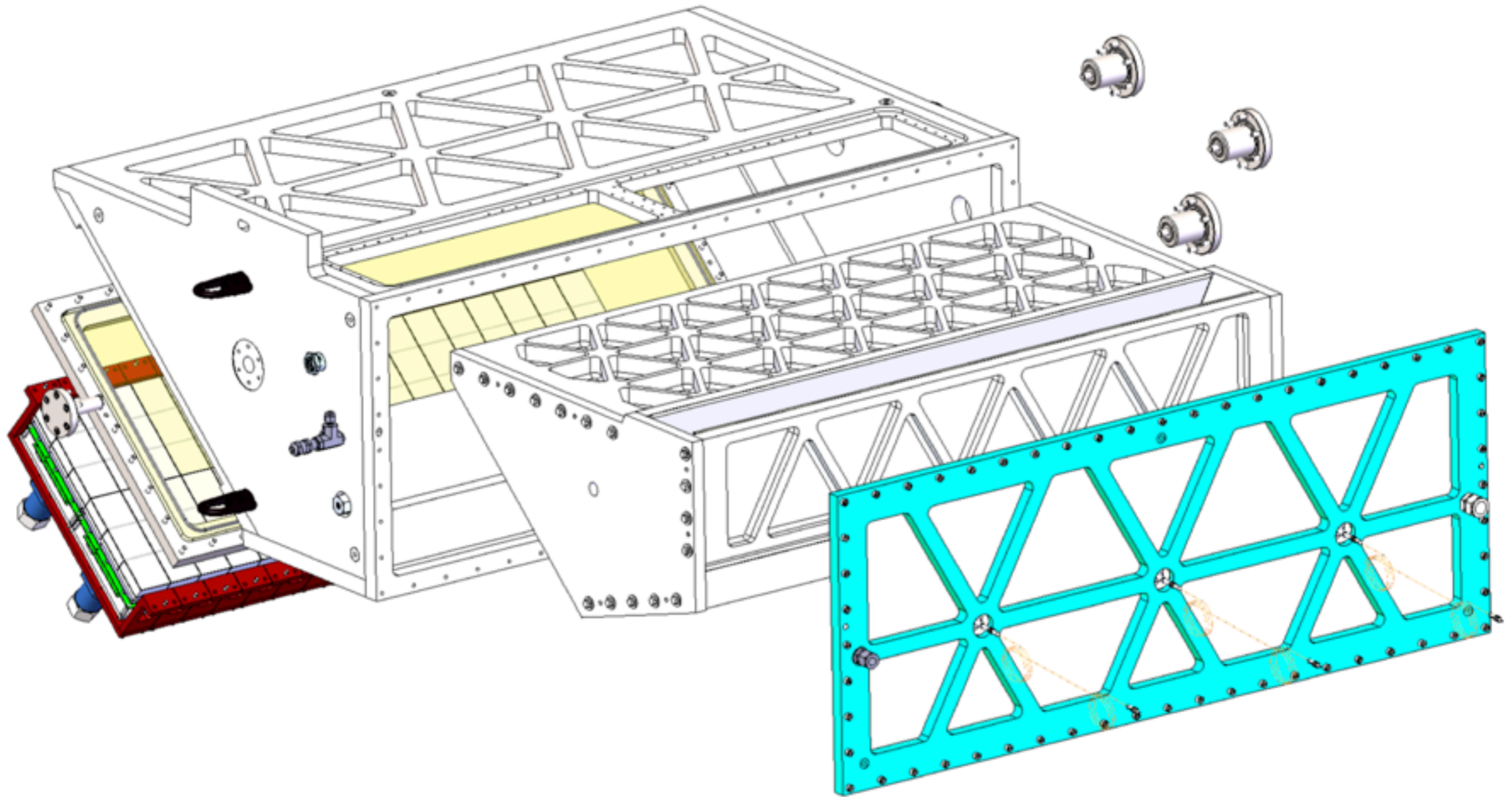

Bar box coupling

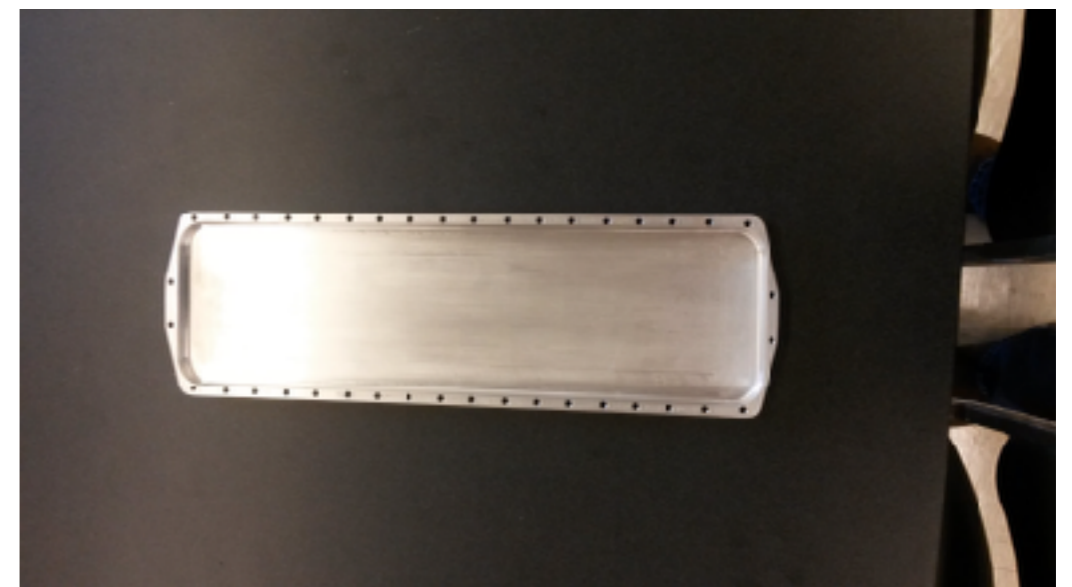
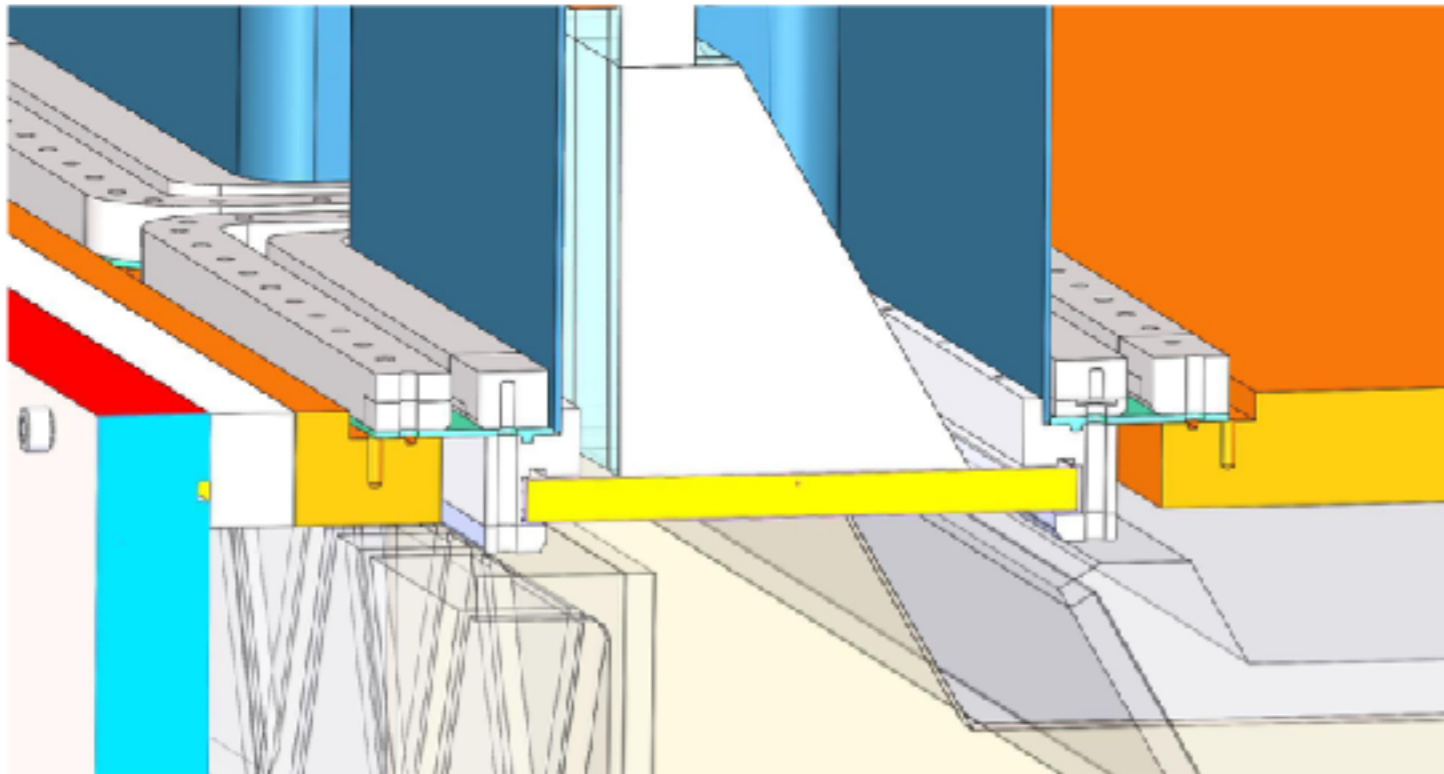

- * New gasket designed and procured at MIT
- * Will be used in optical box leak tests at MIT and in installation of bar boxes JLab

Optical box design

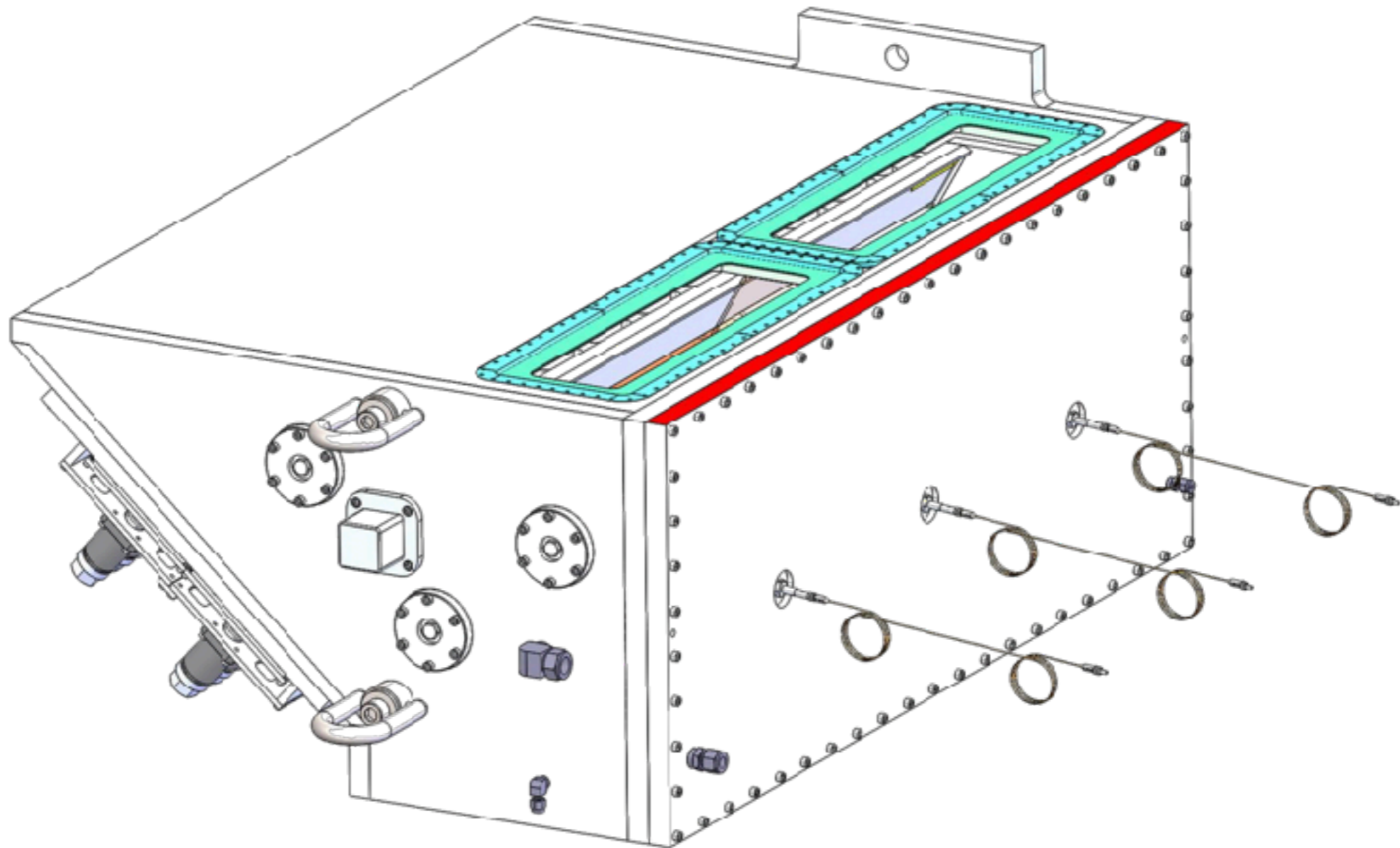

- * Interface with support structure and water system
- * Optical fiber ports for calibration light source

MAPMT installation

- * 18 rows (2 modules each) are mounted to each optical box through an assembled bracket
- * Prototype bracket at MIT-bates: testing coupling with optical cookies to dummy window
- * Production of components for all brackets underway

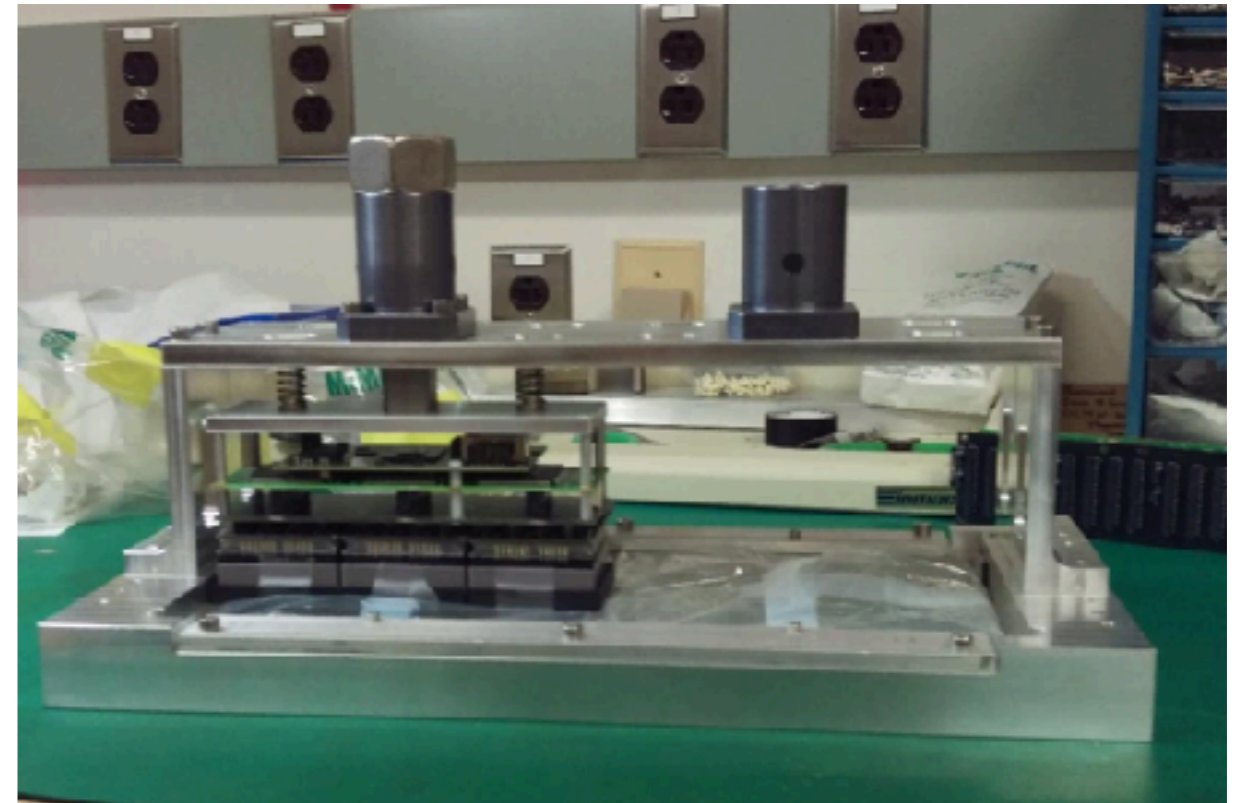
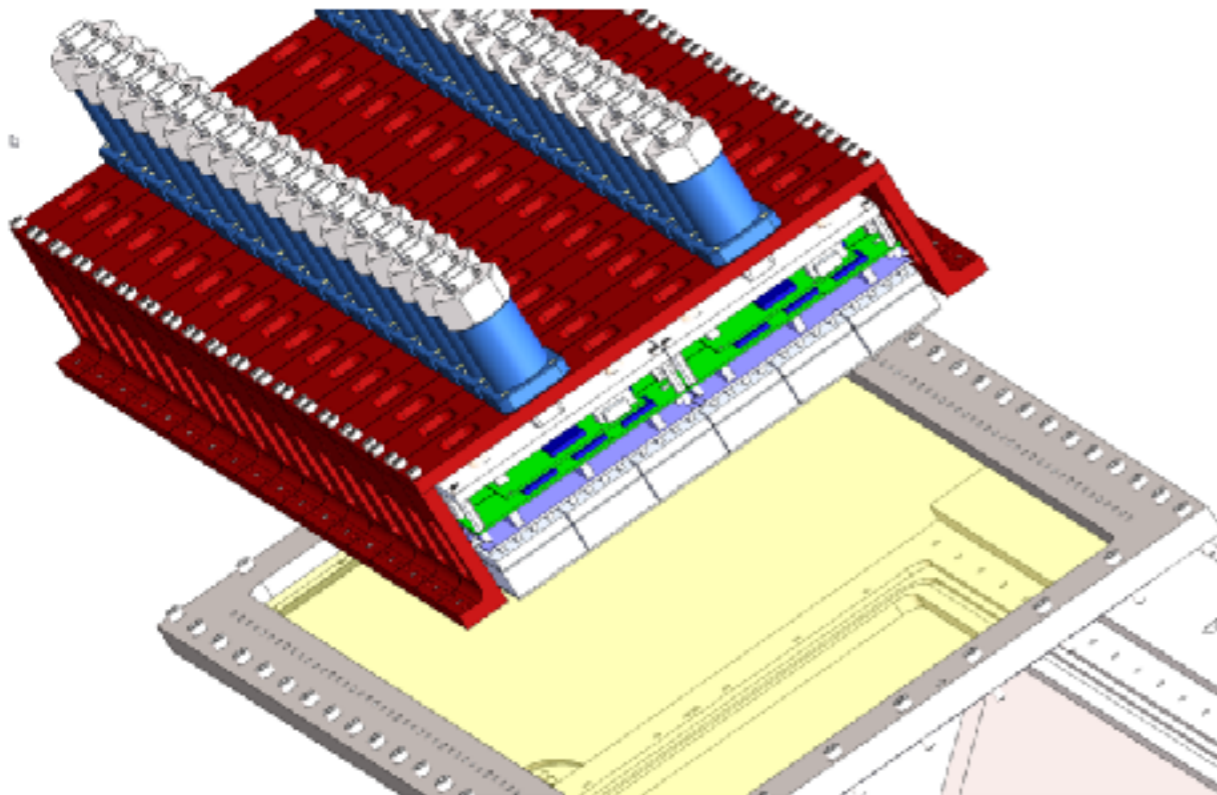

Dark box

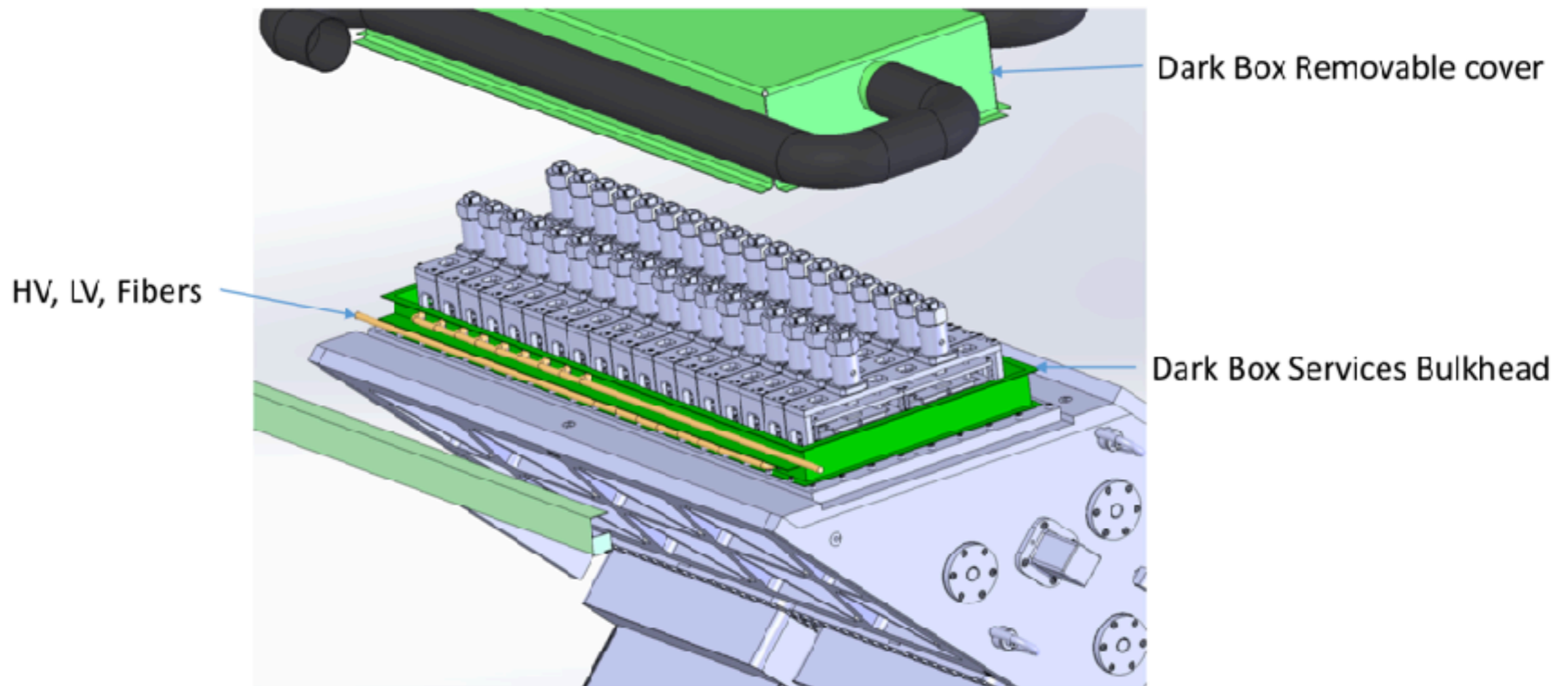

- ✱ Provides light tight environment for PMTs and cooling for electronics in the enclosed environment
- ✱ Interlock HV with proximity sensor and temperature sensors to protect PMTs and electronics

Dark box

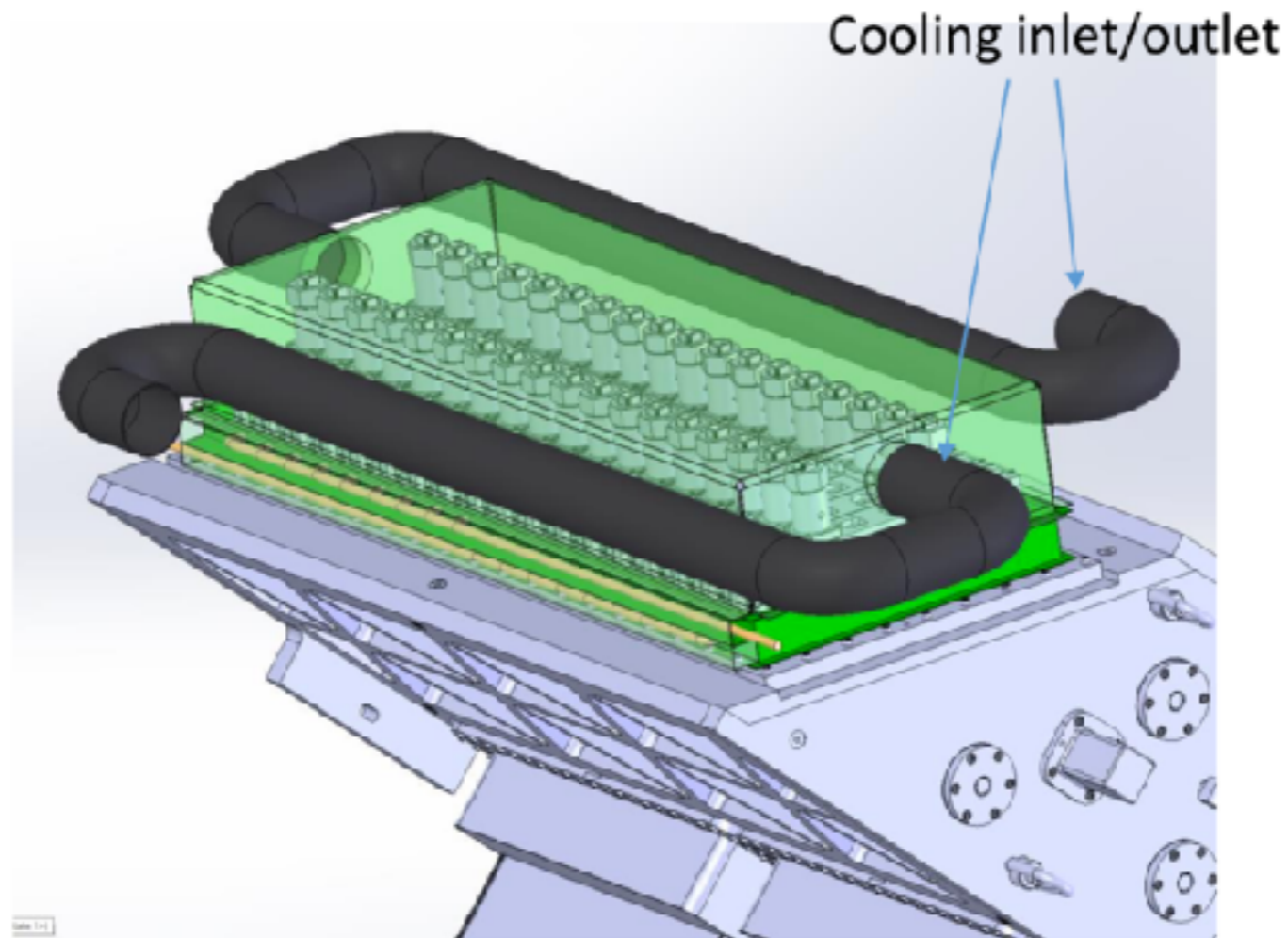

- ✱ Provides light tight environment for PMTs and cooling for electronics in the enclosed environment
- ✱ Interlock HV with proximity sensor and temperature sensors to protect PMTs and electronics

Optical box fabrication schedule

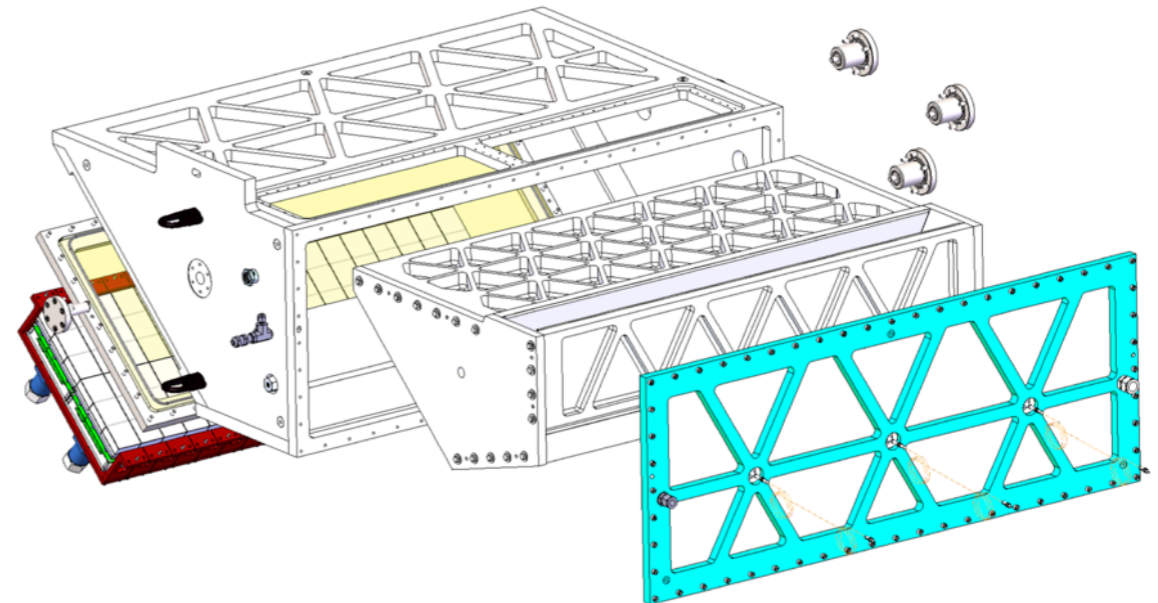

- * Water system at JLab ready for optical box install
- * Outer box being fabricated at vendor and delivery to Bates is expected July 1
- * Mirror strongbacks fabricated and delivered to Bates
- * Delivery of completed optical box expect July 14
- * Expect quartz window delivered to JLab by July 24

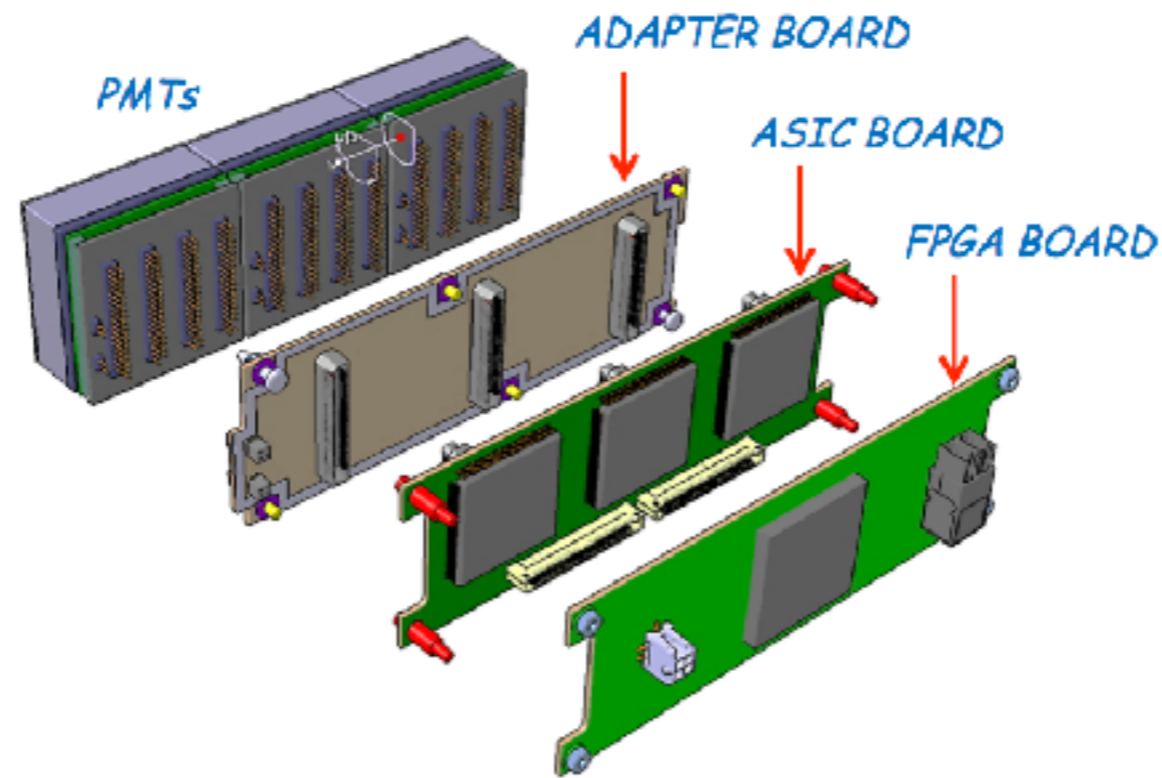

Electronics and MAPMTs



WILLIAM & MARY
CHARTERED 1693

Jefferson Lab

MAPMTs

- * Full order for 210 H12700 MAPMTs placed in November 2017: (180 required + 30 spares)
- * Production/delivery faster than initially expected:
 - * 170 MAPMTs delivered so far (~40/month), so order should be complete by August



Readout electronics and cables

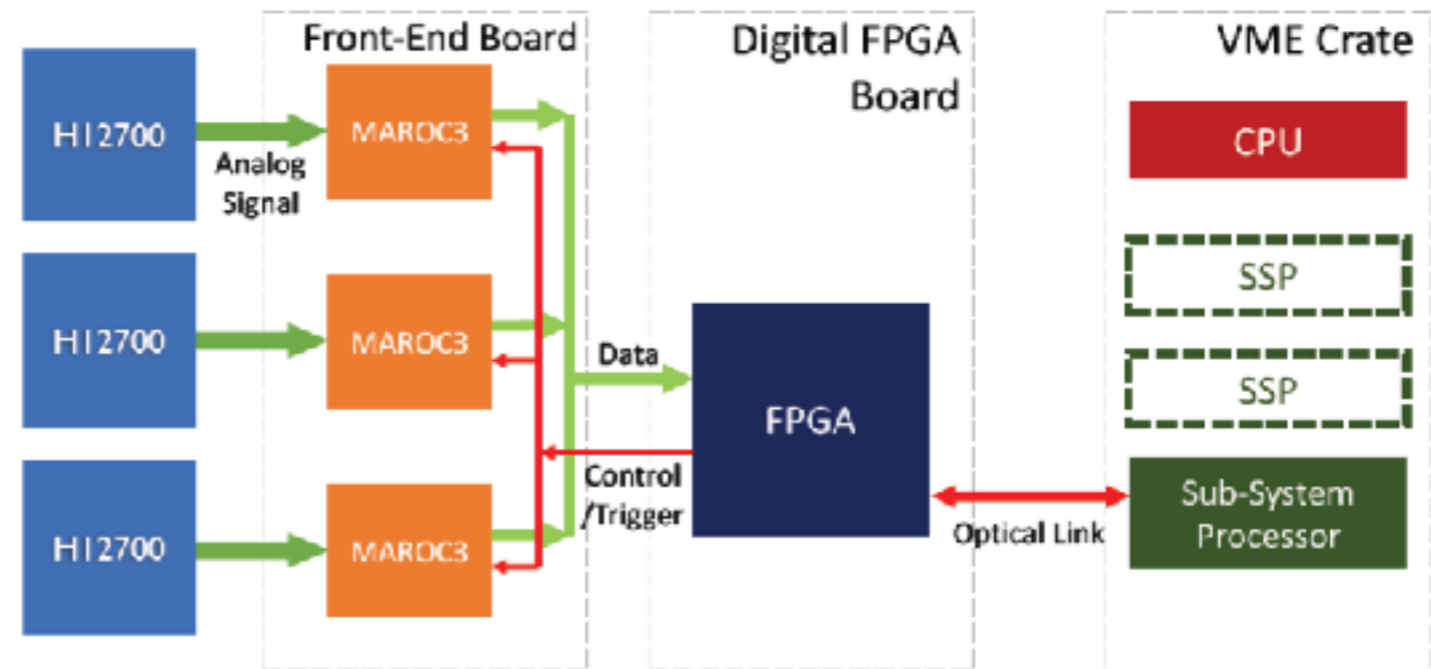

- * All readout components for Fall 2018 installation are in hand at JLab or will arrive before August installation
- * All ASIC, Adapter, FPGA boards at JLab and undergoing testing with MAPMT modules as they arrive
- * Some remaining components (HV, LV, etc.) needed for January 2019 will be purchased later this year

PMT testing and calibration data

- * Continuous testing in laser setup provided by Valery K. (Hall B RICH) since February 2018
- * Integrated test of PMTs, ASIC, and boards
- * Few minor failures with FPGA boards identified
- * Determining timing resolution, gain, and efficiency for each pixel to be used in reconstruction

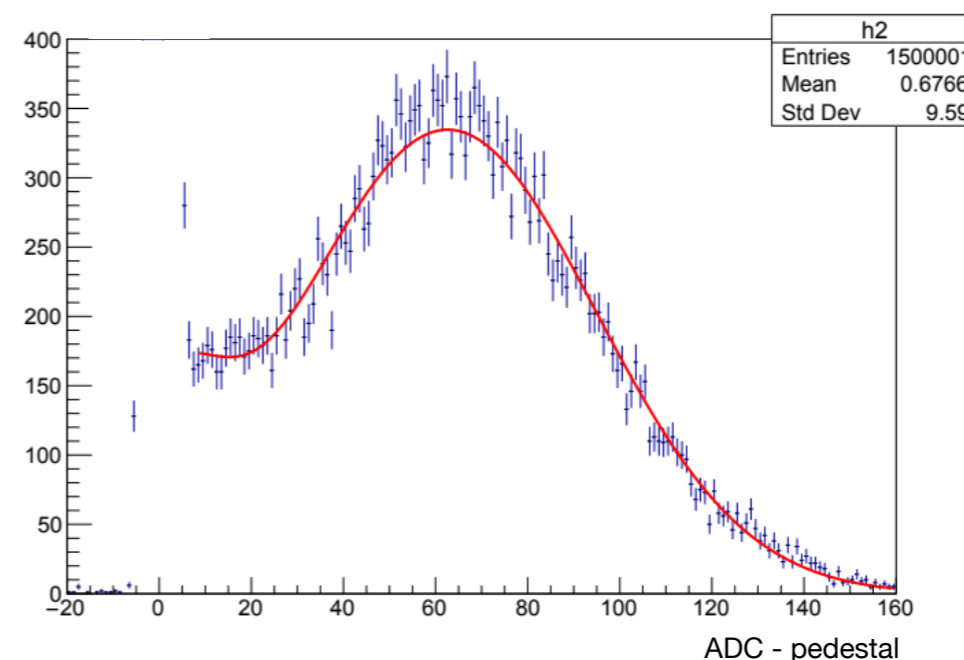
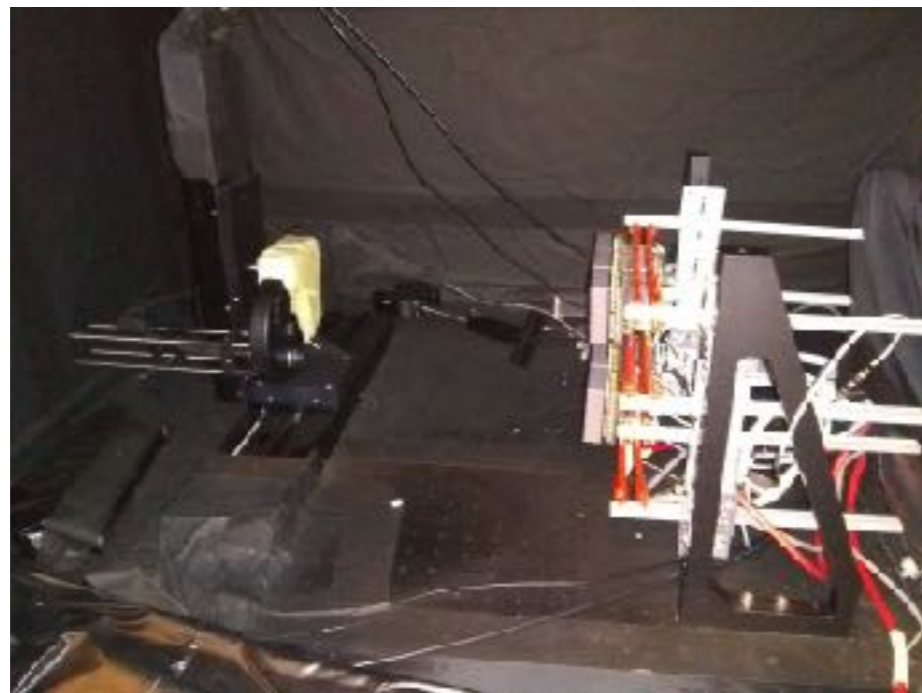

Cabling

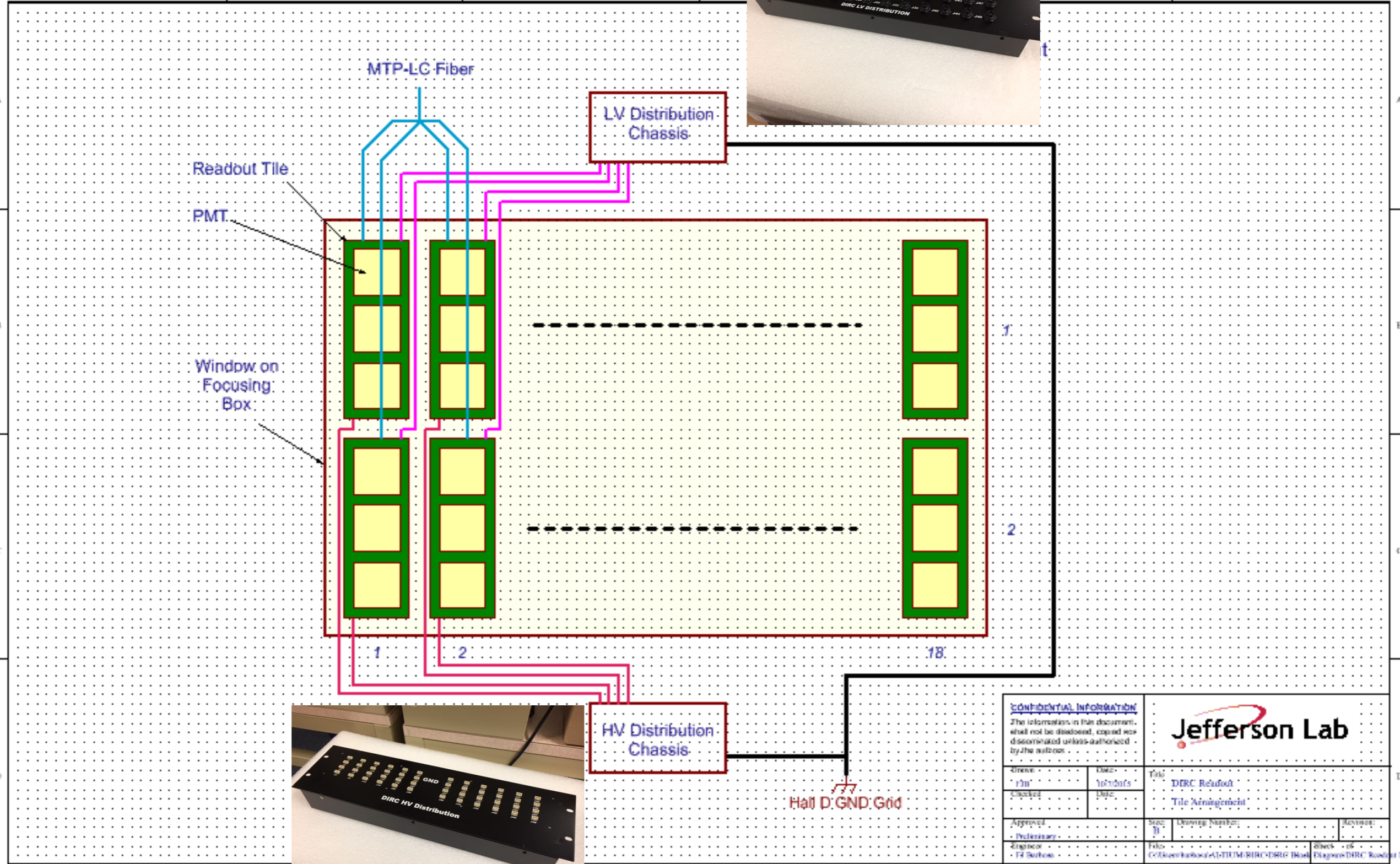

CONFIDENTIAL INFORMATION The information in this document shall not be disclosed, copied or disseminated unless authorized by the author.			
Drawn: rfu	Date: 10/12/05	Title: DIRC Readout Tile Arrangement	
Checked:	Date:	Approved: Preliminary	
Approved: Preliminary	Engineer: T2 Burton	Sheet: 04	Revision:
File: C:\Users\karkov\ATUM\DIRC\DIRC Readout Tile Arrangement		Sheet: 04	

Cabling and DAQ

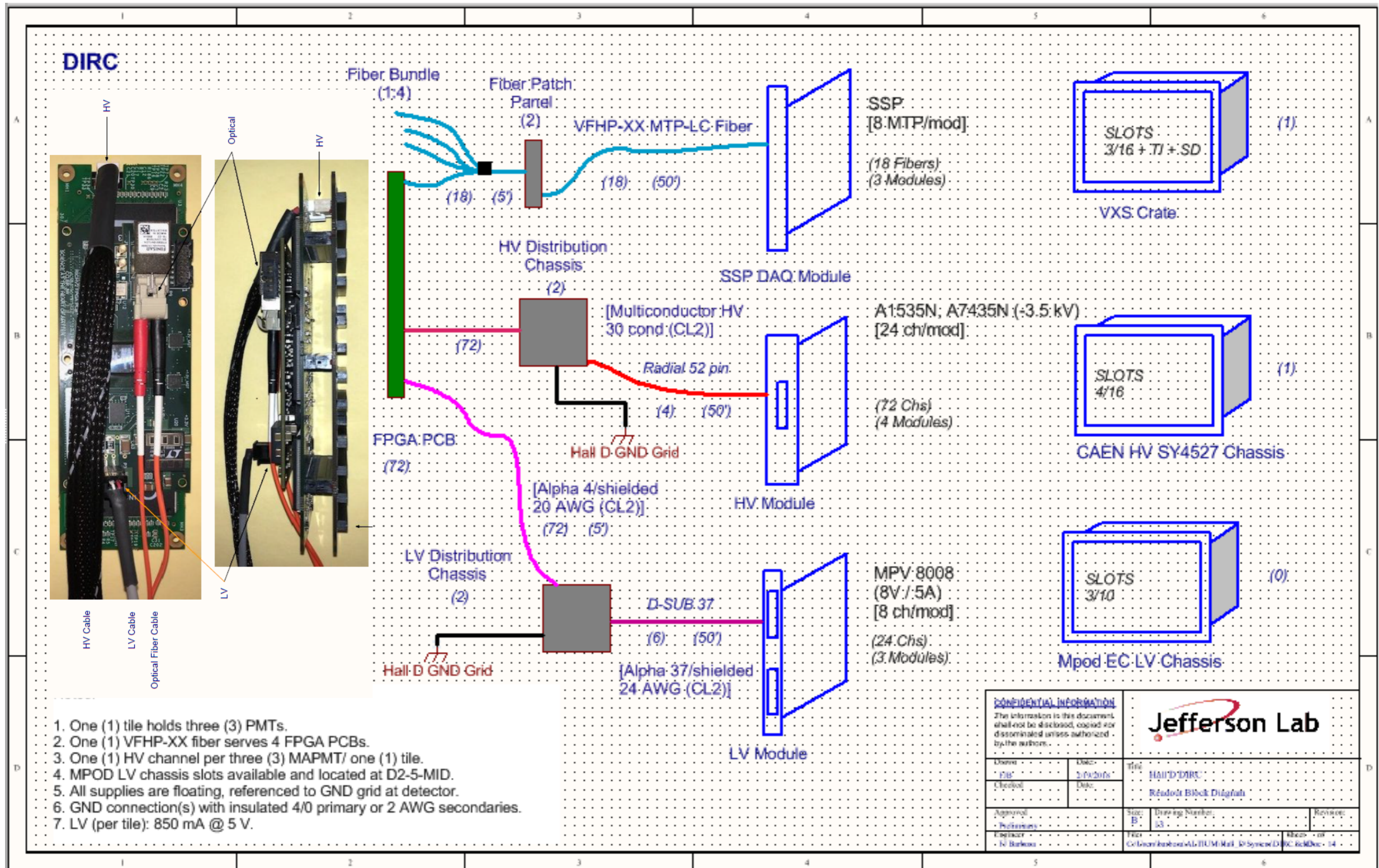

Hazards and Mitigations

Hazards	Mitigation/Controls
Exposure to high voltage or damage to MAPMTs	Dark box enclosure interlock turns off HV and LV through proximity sensor
Elevated temperature in dark box enclosure	Air cooling to remove excess heat, interlock system to turn off HV and LV if system is off or temperature exceeds threshold
Nitrogen purge system: pressure and ODH	Very low flow (< 5 L/hr), ODH alarms in the hall
Water system: pressurized fluid	Maximum pressure of pump is 35 psi, very low stored energy

Calibration and commissioning



Calibration goals

- * MAPMT characterization prior to installation with the Hall B RICH laser setup (described previously)
- * In-situ monitoring of gain and timing calibrations during the experiment
- * Determination of final geometric alignment of optical components, utilizing pure samples of different particle types collected during the commissioning period

Calibration light source

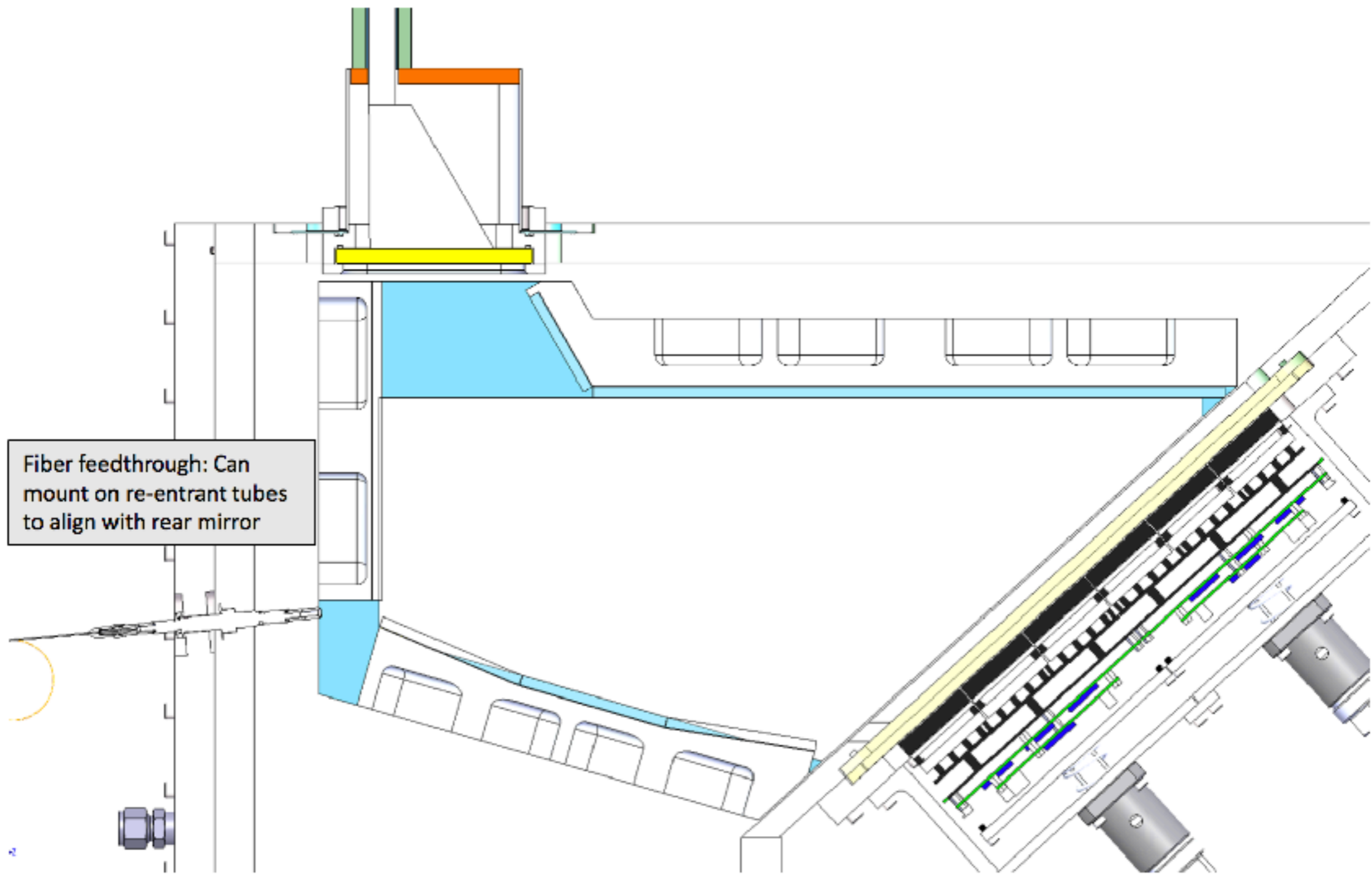

Calibration source optimization

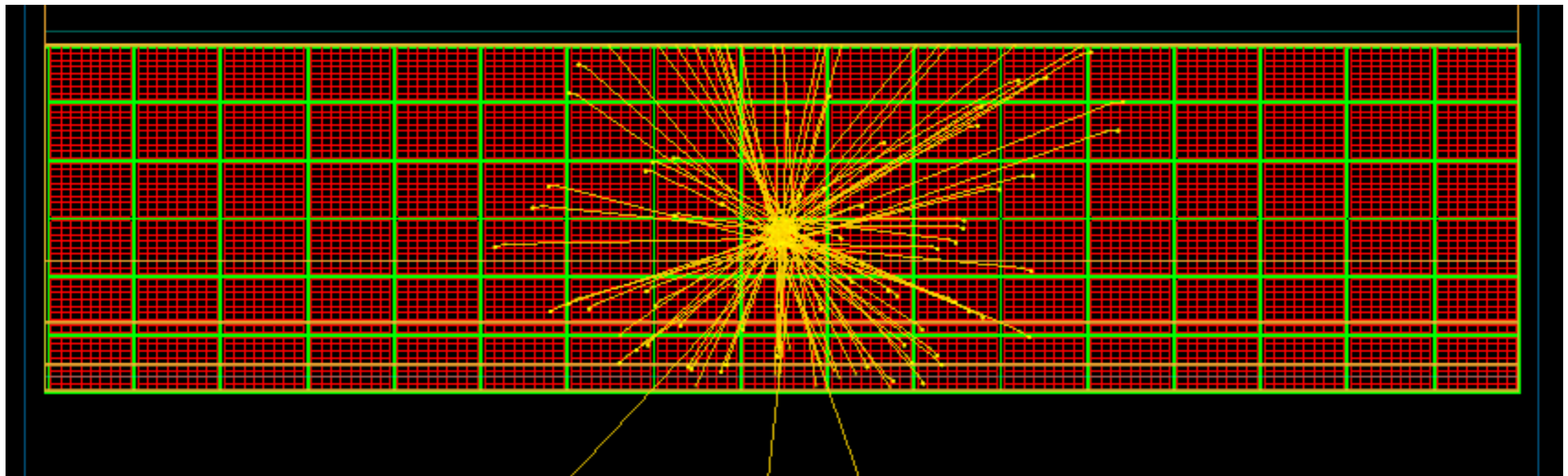
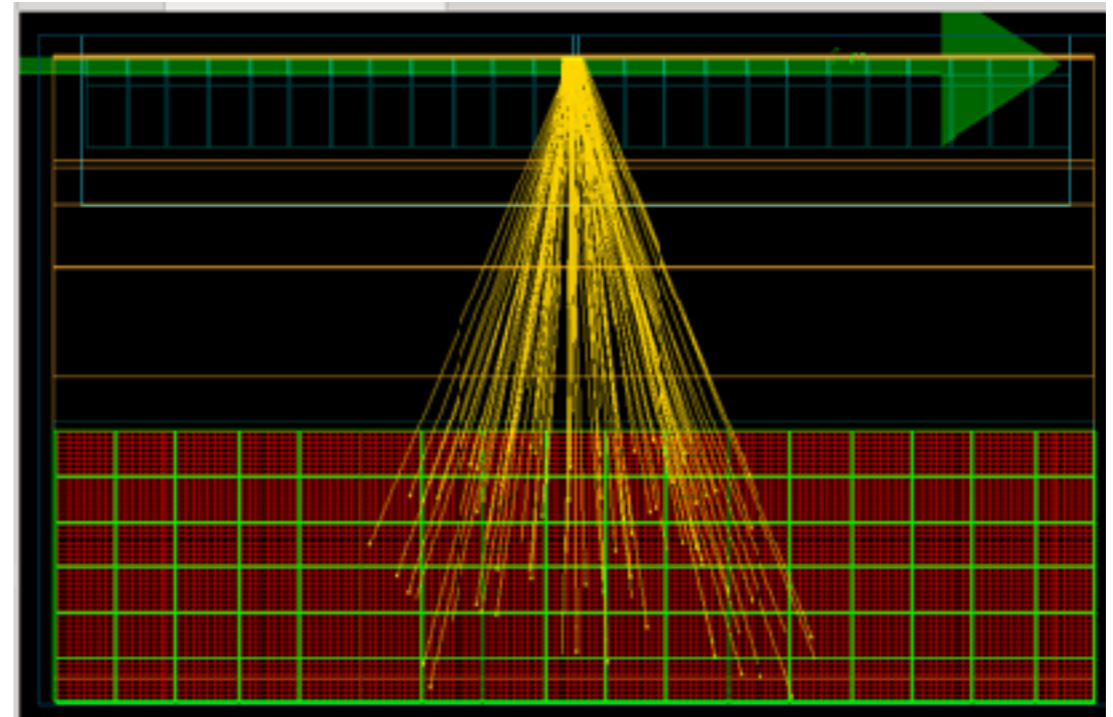
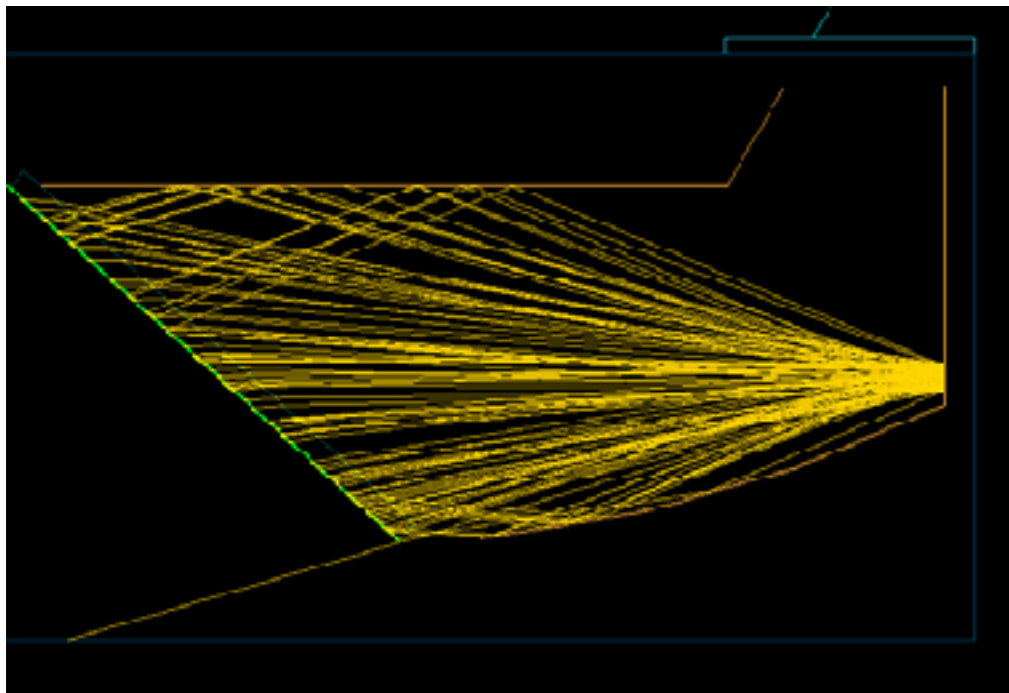

* Optimize opening angle, # fibers, etc... studies @ GSI

Calibration source optimization

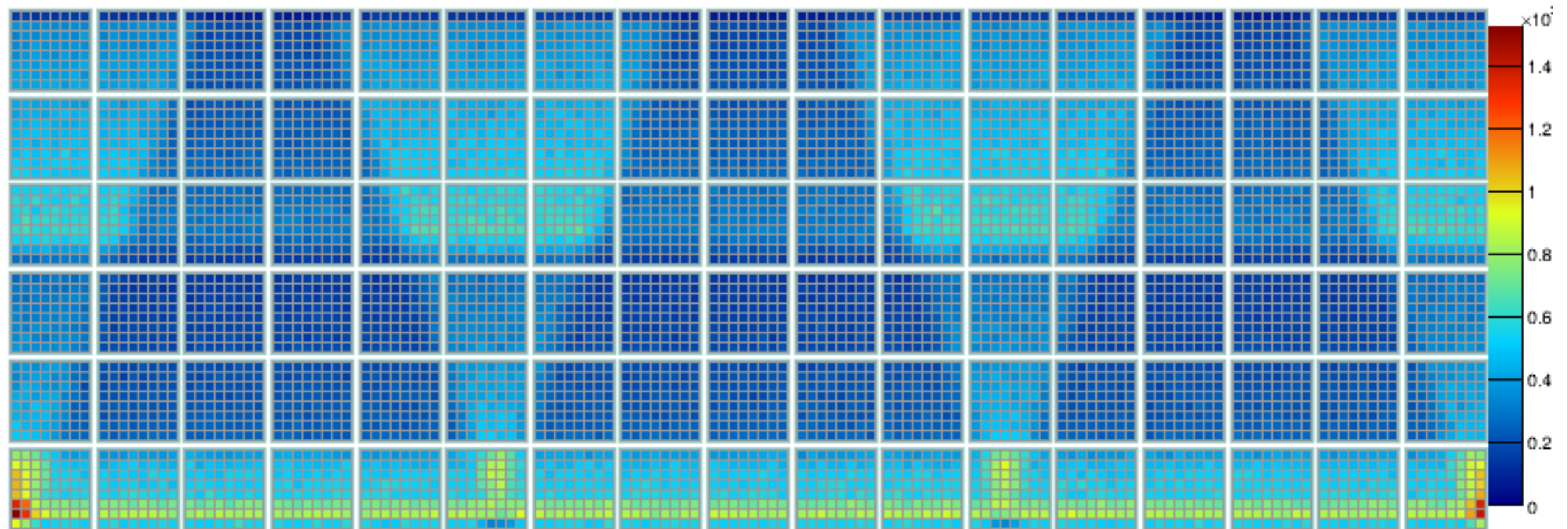

- * 3 fibers with a lens or square diffuser provides full illumination of the MAPMT plane
- * Timing characteristics of LED light source provides sufficient measurement of each pixel's t_0

Calibration system

DIRC Calibration System

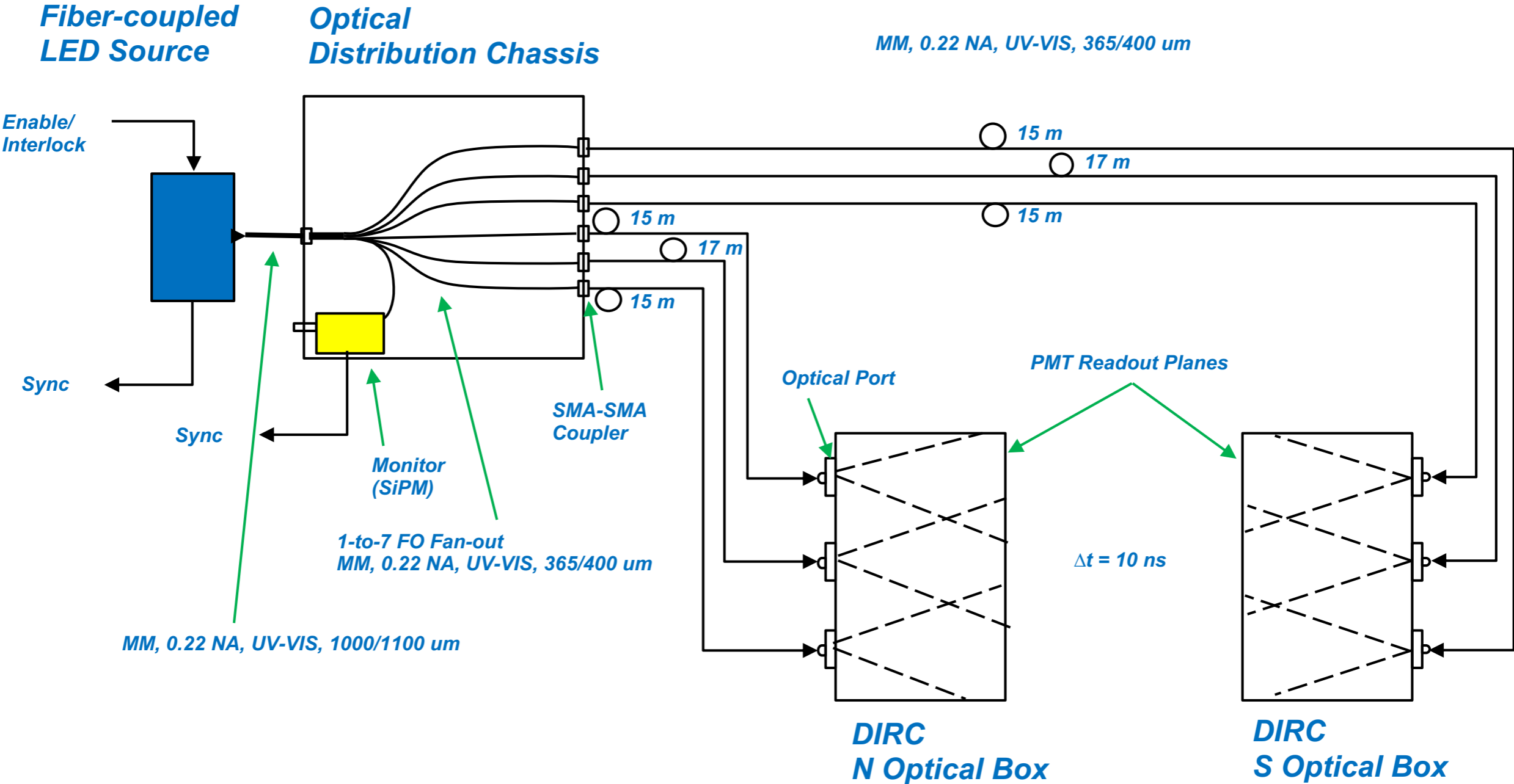

Fernando Barbosa

Commissioning program

- * **Initial commissioning without beam:**

- * Calibrate timing provided by LED system
- * Integrate readout electronics into DAQ

- * **Commissioning with beam:**

- * Collect samples of cleanly identified events with well measured tracks: e.g. $K_s \rightarrow \pi^+ \pi^-$, $\phi \rightarrow K^+ K^-$
- * Implement reconstruction algorithm and compare with simulation: # detected photons, θ_C resolution
- * Determine geometric alignment parameters using pure samples of known particle ID

Reconstruction status

- ✱ For commissioning, plan to utilize Look Up Table (LUT) algorithm similar to that developed at SLAC
- ✱ Fully implemented in GlueX reconstruction software: studies of commissioning simulation planned
- ✱ Future improvements with “time-based” imaging, to include time in 3D PDF expected

Single photon θ_c resolution

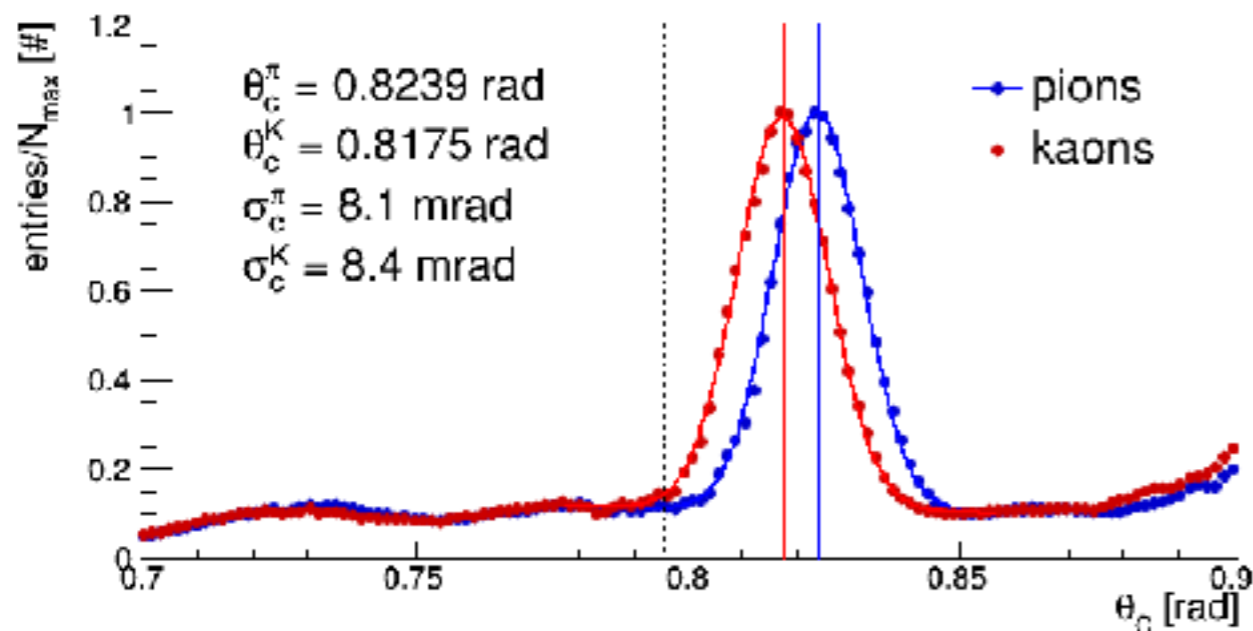

π/K separation power

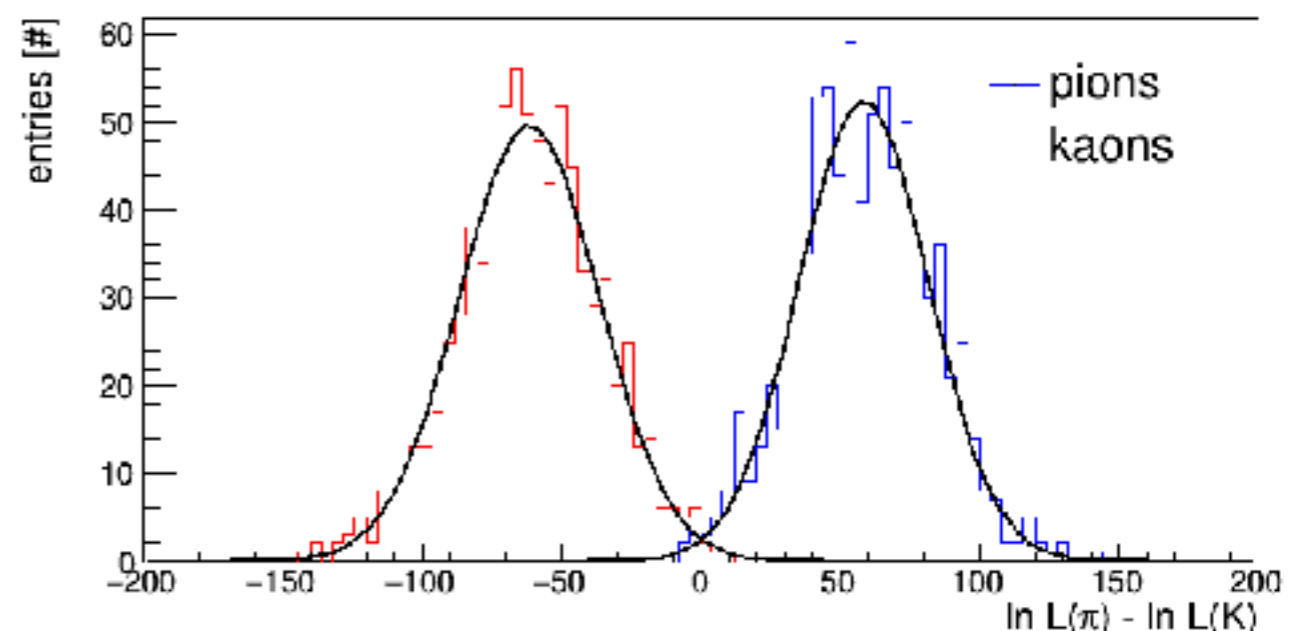

The DIRC team and responsibilities

System	Names	Institution
MAPMT	Wenliang Li Justin Stevens	William & Mary
Electronics/Cabling	Fernando Barbosa Electronics Group	Jefferson Lab
Controls	Nick Sandoval Hovanes Egiyan	Jefferson Lab
Mechanical	Tim Whitlatch Mark Stevens	Jefferson Lab
Calibration/Analysis	DIRC analysis group	MIT, W&M, CUA, GSI

Upcoming schedule

- * **July/August 2018:** 1st optical box delivered and installed before Fall 2018 run
- * **November/December 2018:** Initial commissioning with ~half of detector installed
- * **January 2019:** Complete installation with 2 more bar boxes and 2nd optical box before PrimeX run
- * **Spring/Summer 2019:** Analysis of commissioning data and final checkout of full detector
- * **Fall 2019:** Begin GlueX-II running with DIRC

Summary

- * BaBar bar boxes successfully transported from SLAC to JLab and installed on the support structure
- * All PMTs and electronics required for the commissioning setup are acquired and tested
- * Fabrication of the 1st optical box is ongoing at Bates and installation is contingent on this completion
- * Installation of 1/2 of detector is expected to be completed in Fall 2018
- * Commissioning of 1/2 of the detector will begin in November 2018, and full installation before GlueX-II physics running begins in Fall 2019

Backup

Project Schedule

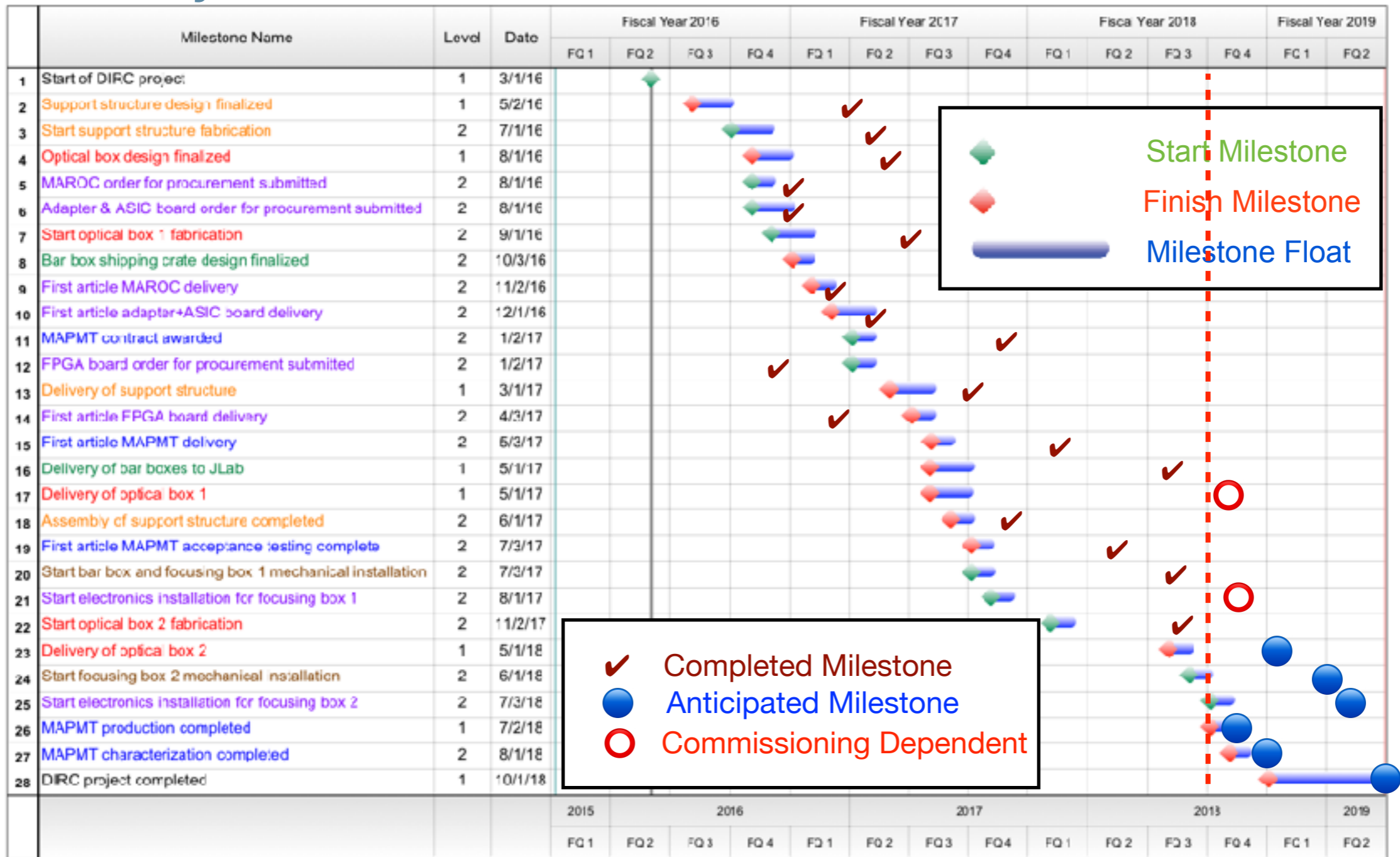

Hall D Timeline

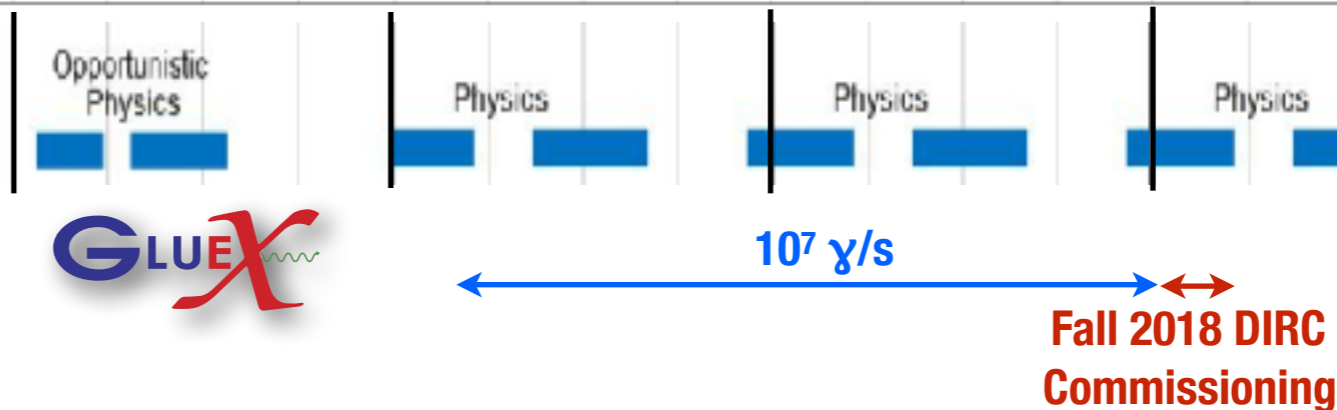

Spring 2019 η Primakoff

Particle Identification: DIRC

- * **DIRC:** Detection of Internally Reflected Cherenkov Light
- * Pioneered for BaBar detector at SLAC PEP-II
- * Image photons to measure Cherenkov angle

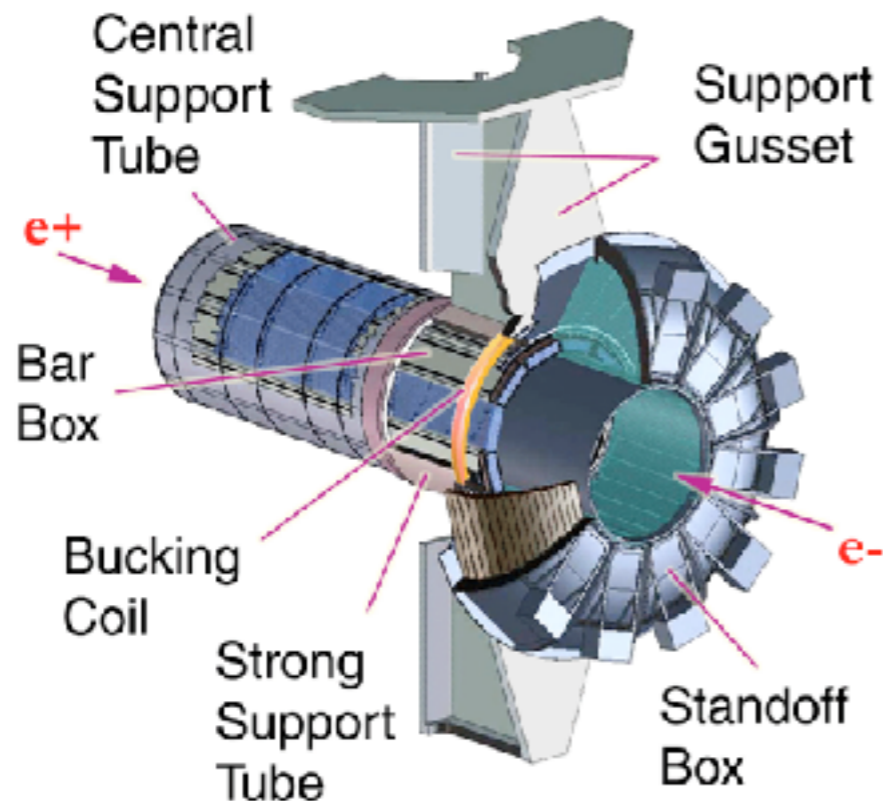
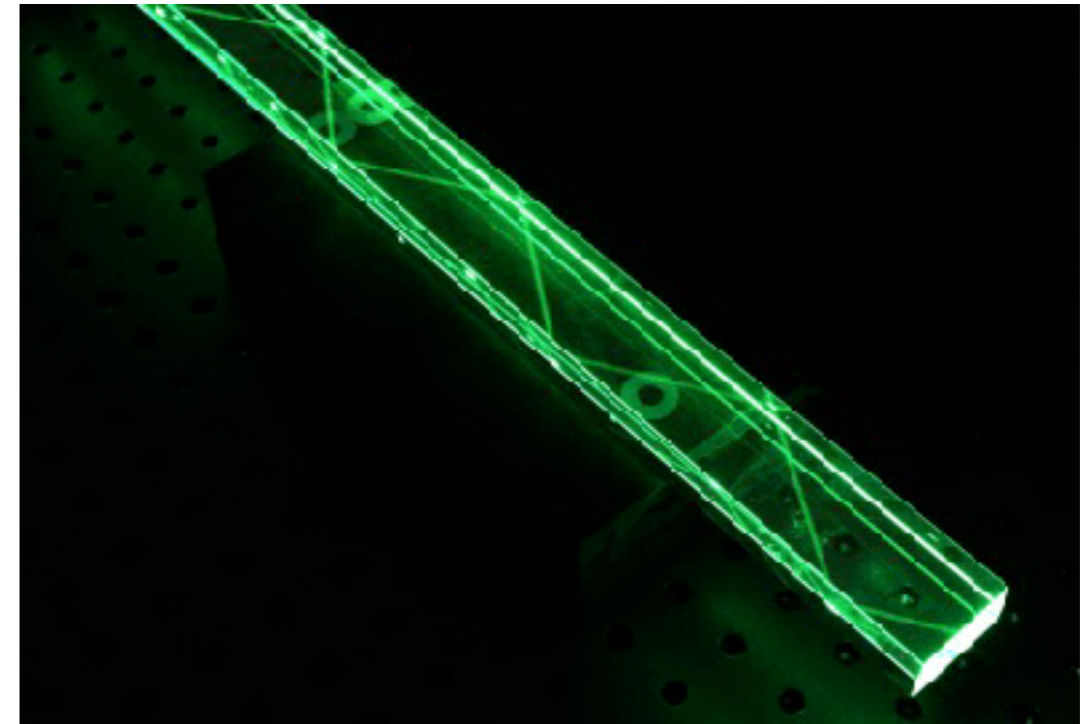

BaBar DIRC Event Display

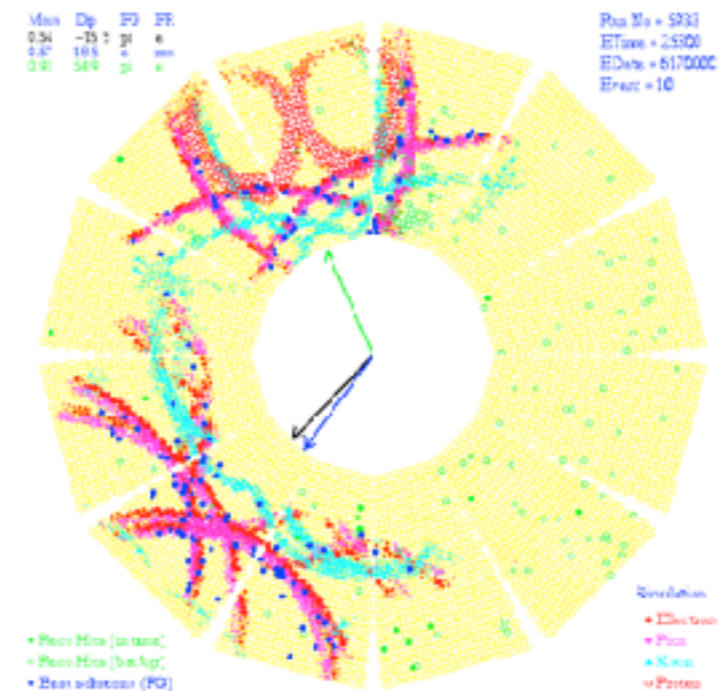

Real time monitoring

- ✱ Distinct kaleidoscope patten when viewing bar from window which can be monitored in ~real time
- ✱ Accelerometer data in real time to assess any shocks which exceeded safety limits

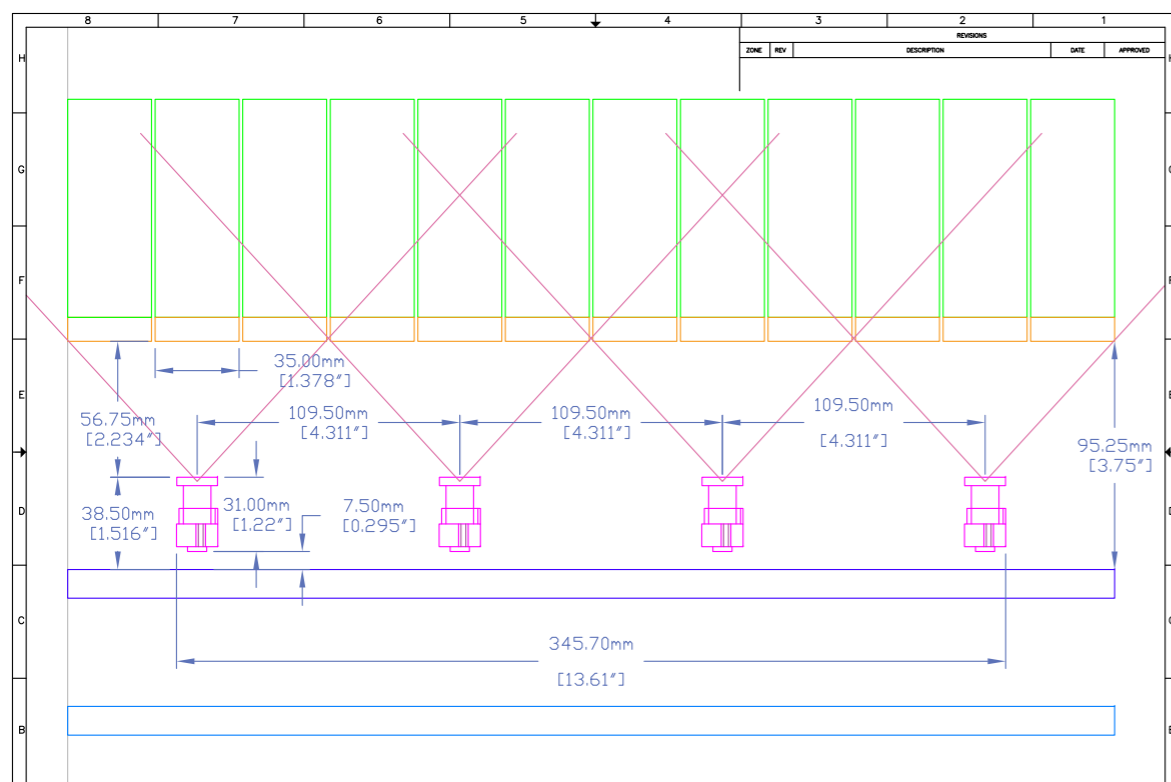

Manpower considerations

- * Electronics & cabling installation: Hall D electronics group
- * Optical box fabrication: Bates
- * Optical box installation: Bates and Hall D mechanical
 - * PMT module installation: Bates, MIT, W&M, CUA
- * **Commissioning tasks**
 - * MAPMT laser test data analysis (underway): W&M
 - * Timing calibrations: GSI and W&M
 - * Reconstruction implementation: GSI, MIT and W&M
 - * Detector alignment: MIT and W&M

Commissioning datasets

- * **HV and threshold scans** (~4 days)
 - * Collect datasets with similar set of HV, MAROC gain, and threshold settings
 - * Validate MAPMT characterization with both LED calibration and beam data
- * **Intensity dependence** (~4 days)
 - * Evaluate rate dependence and backgrounds for both high and low luminosity
 - * Coherent peak photon flux from 1×10^7 (GlueX I) to 5×10^7 (GlueX II)

EHS&Q Documentation

- * ESAD and COO updated to include DIRC
- * OSP submitted and detailed shift worker instructions to come with screenshots of HV GUIs, etc.
- * **Expect updates to:**
 - * RSAD: Consult with RadCon with expected running conditions prior to run (expect similar to Spring 2017)
 - * ERG: Will include final drawings with DIRC in safety and evacuation plans