



12000 Jefferson Avenue

SPECIFICATION NO:

D00000-02-02S001Rev-

Newport News, VA 23606

**TITLE: Goniometer and controller
Specification for Hall D**

DATE: July 13, 2012

BY: Ken Livingston

APP: Alex Somov 10/2012
Alex Somov Date
SOTR

APP: E. Chudakov 10/2012
Eugene Chudakov Date
Hall D Group Leader

APP: T E Whitlatch 10/2012
Tim Whitlatch Date
Hall D Engineer

TABLE OF CONTENTS

1.0	SCOPE	3
2.0	APPLICABLE DOCUMENTS	3
3.0	TECHNICAL REQUIREMENTS	3
4.0	QUALITY REQUIREMENTS	4
5.0	HANDLING, PACKING, AND DELIVERY	5

1.0 SCOPE The Thomas Jefferson National Accelerator Facility (JLab) is engaged in a project to double the energy of their accelerator from 6 to 12 GeV. This project also includes upgrades to the experimental equipment in the three experimental areas A, B, and C, as well as the construction of a fourth experimental area D. The new beam facilities and the improved detection system will be used to carry out the proposed scientific program. JLab is a nuclear physics research laboratory managed and operated by Jefferson Science Associates for the U. S. Department of Energy.

1.1. Statement of Work The selected vendor shall provide a 5 axis motion system (goniometer) and controller with dimensions and other properties as specified in this document. In addition the vendor shall assemble and test the system and deliver all documentation required in this specification.

2.0 APPLICABLE DOCUMENTS

2.1. Design Documents

2.1.1. Goniometer schematic. A schematic of a possible configuration for the goniometer and electron beam based on one currently in use at another lab. The schematic shows all applicable axis.(Fig 1)

3.0 TECHNICAL REQUIREMENTS The goniometer will sit in a vacuum chamber in a high energy (12GeV) electron beam. The electron beam will strike a crystal mounted on a disk in the center of the goniometer. If the crystal is at the correctly adjusted orientation this will produce linearly polarized photons using the coherent bremsstrahlung technique. A document showing a schematic of a similar goniometer from the University of Mainz, Germany is included. The ordering of the roll and pitch stages is not important provided the following criteria can be met.

- 1.** It should be possible to translate the whole goniometer out of the beam line: 0-200mm x translation. The assembly must clear beamline by 50mm minimum.
- 2.** Several thin crystals will be mounted on a thin disk in the center of the goniometer such that any one of them can be moved into the beam. The minimum diameter for the opening to house the disk is 90mm.
- 3.** It must be possible to select any azimuthal angle of the crystal: roll axis -170 -> +170 deg
- 4.** Very fine adjustment is required on the angle between the electron beam and the crystal planes: yaw and pitch axes. The range on these is +/- 10 deg.
- 5.** All components with travel must fit within a volume of width = 700mm, depth = 500mm, height = 700mm

6. Attachment method to vacuum box shall be proposed by vendor and approved by JLAB.

7. All stages must have backlash of less than the minimum increment of motion.

Note: All components must be Vacuum Compatible to 10^{-6} Torr

The requirements for each axis and controller are given below

3.1. Axis1 Horizontal Linear Translation. (1 required)

Range: 0-200mm, Resolution: 1um, Encoder: Essential, Limit switches at 0, 200mm.

3.2. Axis2 Vertical Linear Translation. (1 required)

Range: 0-100mm, Resolution: 1um, Encoder: Essential, Limit switches at 0, 100mm

3.3. Axis3 Roll. (1 required)

Range: +/-170 deg, Resolution: 0.01 deg, Encoder: Not required, Limit switches adjustable.

3.4. Axis4 Yaw. (1 required)

Range: +/-10 deg, Resolution: 0.0002 deg, Encoder: Not required, Limit switches at +/- 10deg

3.5. Axis5 Pitch. (1 required)

Range: +/-10 deg, Resolution: 0.0002 deg, Encoder: Not required, Limit switches at +/- 10deg

3.6. Drive modules (5 required).

For the above specified axes.

3.7. Controller.

Must be capable of controlling a minimum of 6 axes.

Ethernet communication: Required

Software: Must be compatible with EPICS (Experimental and Industrial Control System)

3.8. Cables

Vacuum compatible cables and connectors to be supplied for each of the specified axis stages.

4.0 QUALITY REQUIREMENTS

- 4.1. **Factory Testing** The manufacturer must test and document the goniometer assembly and controller performance before delivery.
- 4.2. **Acceptance Testing** Acceptance of shipment of the goniometer will take place within 20 working days after receipt of the shipment. Performance of the goniometer and controller will be measured as part of acceptance.

5.0 HANDLING, PACKING, AND DELIVERY

- 5.1. **Shipping Containers** The vendor shall propose the optimal size of shipments.
- 5.2. **Handling** The vendor shall indicate any special handling procedures that would be required.
- 5.3. **Packaging** The goniometer shall be packaged in fully assembled state unless a JLAB approved alternative is agreed upon. The test documentation shall be included with the package. The controller shall be packaged separately with documentation. All items shall be packaged such that no damage or foreign material contamination occurs during shipment.
- 5.4. **Marking** Packages shall be suitably marked on the outside to facilitate identification of purchase order, the procurement specification, the package content, and any special handling instructions.
- 5.5. **Delivery** All packages shall be delivered to **Jefferson Lab as outlined on the Purchase Order**
- 5.6. **Schedule** The shipment shall be due 14 weeks after the subcontract award date

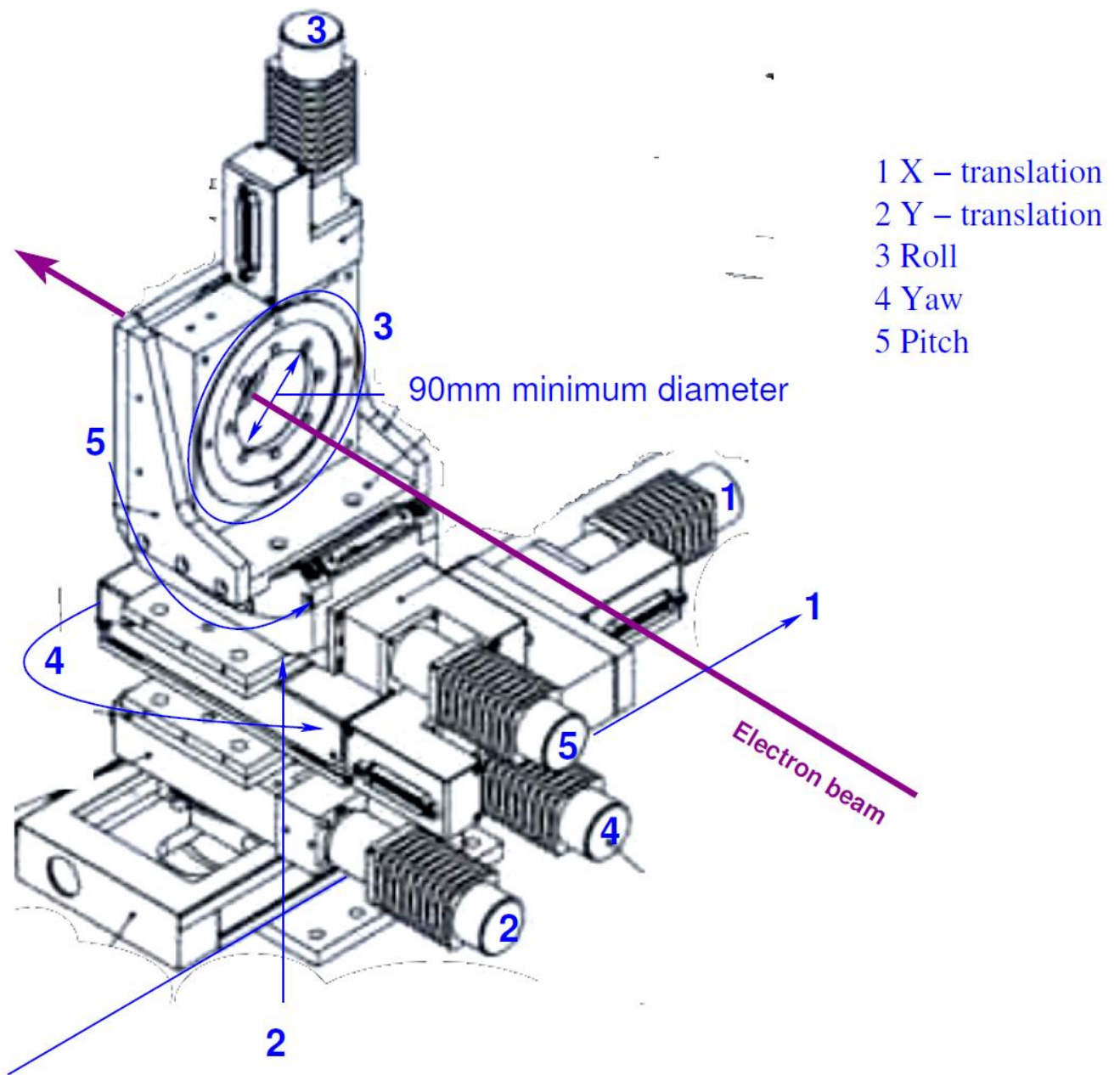

Figure 1. Goniometer schematic