

REVISION HISTORY				
ZONE	REV	DESCRIPTION	DATE	APPROVED

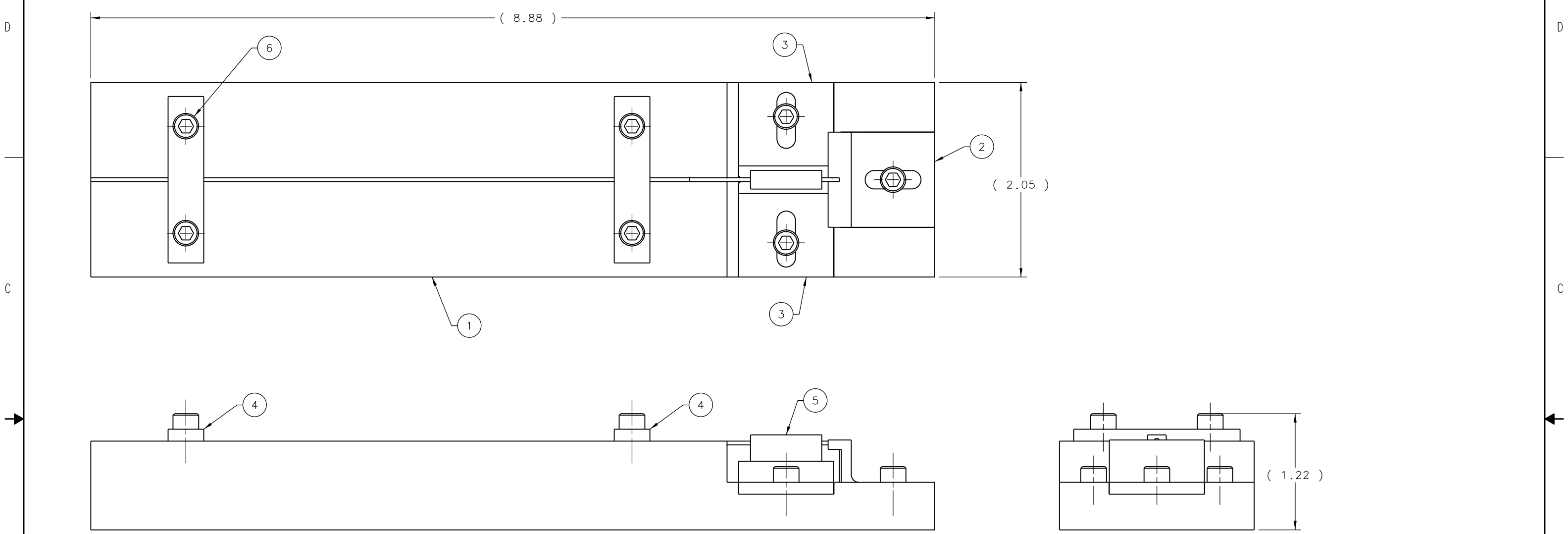

QTY REQD	ITEM NO.	PART OR IDENTIFYING NO.	NOMENCLATURE OR DESCRIPTION	MATERIAL SPECIFICATION	NOTES
7	6	MCMaster-CARR #95868A340	SOC HD CAP SCREW #8-32 X .25 LG	NYLON	
1	5	D00000-15-00-2046	GLUING HOLDER		
2	4	D00000-15-00-2045	WLS STRAP		
2	3	D00000-15-00-2044	HORIZONTAL GLUING SLIDER		
1	2	D00000-15-00-2043	VERTICAL GLUING SLIDER		
1	1	D00000-15-00-2042	VERTICAL GLUING BASE		

PARTS LIST		TRACKING NO.		United States Department of Energy	
SEE PARTS LIST		N/A		Jefferson Lab Thomas Jefferson National Accelerator Facility Newport News Virginia	
APPROVALS		DATE		HALL D - GLUEX SPECTROMETER PAIR SPECTROMETER VERTICAL GLUING FIXTURE ASSY	
DRAWN C L HUTTON		15JAN13		SIZE DWG. NO. D00000-15-00-1011	
CHECKED				REV. -	
APPROVED				SCALE 2/1 USED ON ASSY NO. SHEET 1 OF 1	
APPROVED					

DOCUMENT CONTROL STAMP

FINISH MACHINED SURFACES DEBURR & BREAK ALL SHARP EDGES

125 UNLESS OTHERWISE NOTED

DO NOT SCALE DRAWING

DIM & TOL PER ASME Y14.5 UNLESS OTHERWISE SPECIFIED DIMENSIONS ARE IN INCHES TOLERANCES ARE:

FRACTIONS	DECIMAL	ANGLES
± N/A	X ± .1	± .50°
	.XX ± .01	
	.XXX ± .005	

THIRD ANGLE PROJECTION

APPROVALS

DATE

15JAN13

United States Department of Energy

Jefferson Lab
Thomas Jefferson National Accelerator Facility
Newport News Virginia

HALL D - GLUEX SPECTROMETER PAIR SPECTROMETER VERTICAL GLUING FIXTURE ASSY

SIZE DWG. NO. D00000-15-00-1011

REV. -

SCALE 2/1 USED ON ASSY NO. SHEET 1 OF 1

REVISION HISTORY				
ZONE	REV	DESCRIPTION	DATE	APPROVED

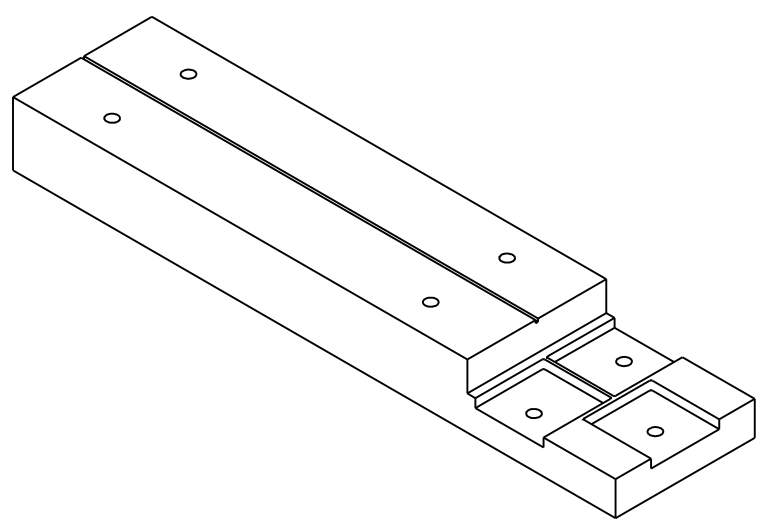
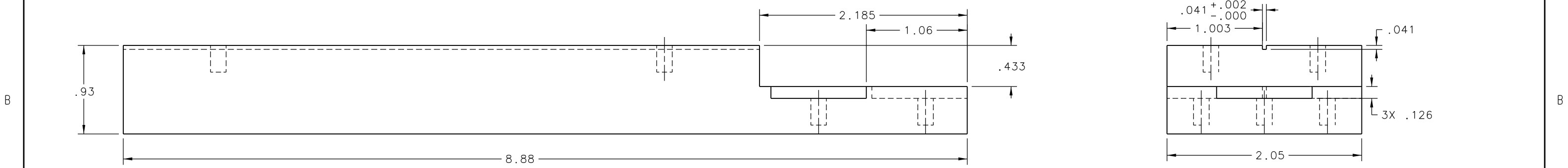
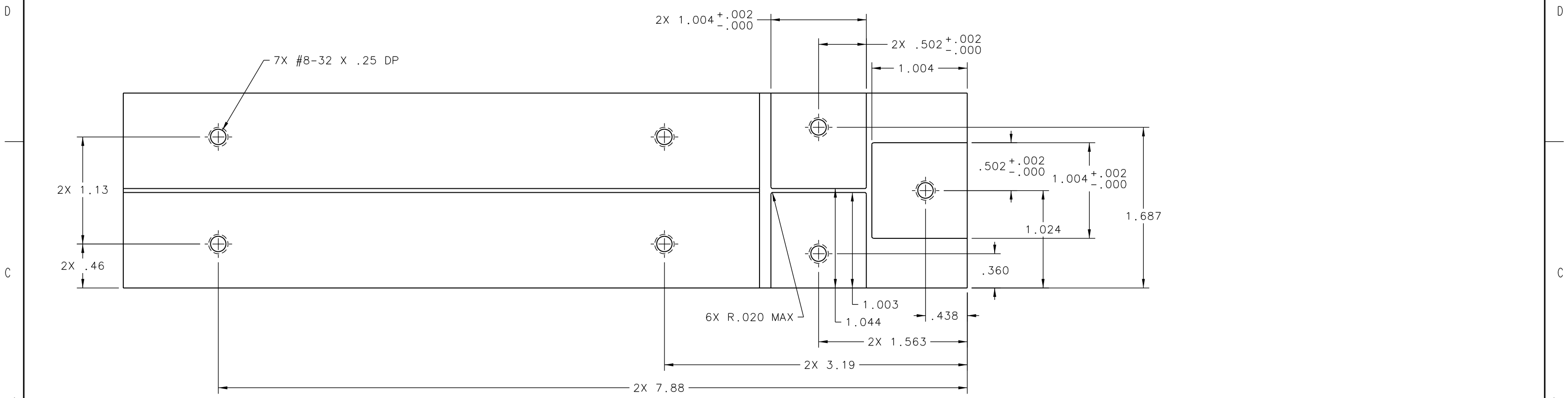

DOCUMENT CONTROL STAMP	DIM & TOL PER ASME Y14.5 UNLESS OTHERWISE SPECIFIED DIMENSIONS ARE IN INCHES TOLERANCES ARE: FRACTIONS DECIMAL ANGLES ± N/A .X ± .1 ± .50° .XX ± .01 .XXX ± .005	TRACKING NO. N/A	United States Department of Energy	Jefferson Lab Thomas Jefferson National Accelerator Facility	Newport News Virginia
MATERIAL DELTRIN	THIRD ANGLE PROJECTION	APPROVALS DRAWN C L HUTTON	DATE 11JAN13	HALL D - GLUEX SPECTROMETER PAIR SPECTROMETER VERTICAL GLUING BASE	
FINISH MACHINED SURFACES DEBURR & BREAK ALL SHARP EDGES	125 ✓ UNLESS OTHERWISE NOTED	CHECKED	APPROVED	SIZE D	DWG. NO. D00000-15-00-2042
DO NOT SCALE DRAWING		APPROVED	SCALE 2/1	USED ON ASSY NO. D00000-15-00-1011	SHEET 1 OF 1

4

3

2

1

REVISION HISTORY				
ZONE	REV	DESCRIPTION	DATE	APPROVED

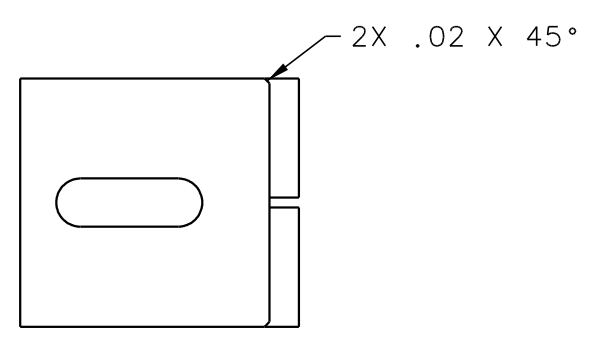
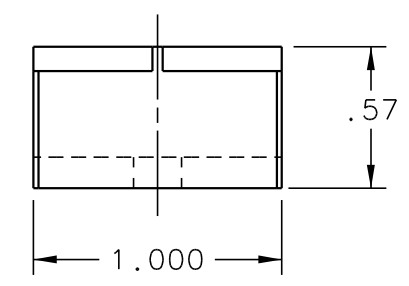
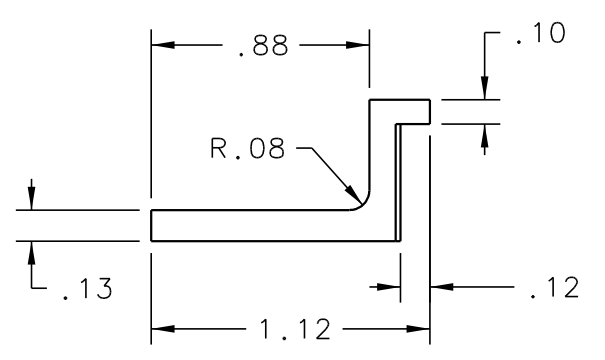
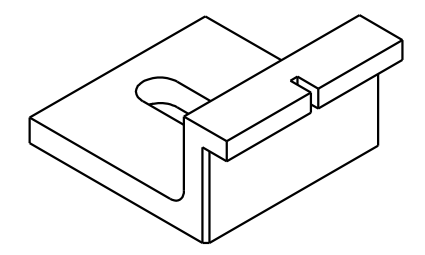
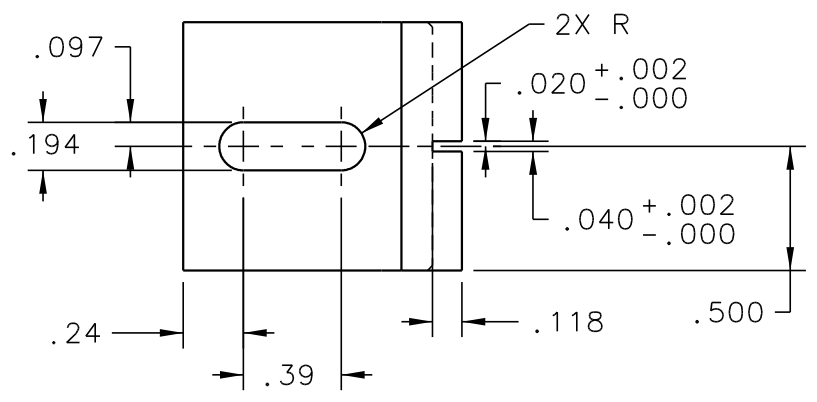

DOCUMENT CONTROL STAMP	DIM & TOL PER ASME Y14.5 . UNLESS OTHERWISE SPECIFIED DIMENSIONS ARE IN INCHES TOLERANCES ARE: FRACTIONS DECIMAL ANGLES ± N/A .X ± .1 ± .50° .XX ± .01 .XXX ± .005	TRACKING NO. N/A	United States Department of Energy	Jefferson Lab Thomas Jefferson National Accelerator Facility	Newport News Virginia
MATERIAL DELTRIN	THIRD ANGLE PROJECTION	APPROVALS	DATE	HALL D - GLUEX SPECTROMETER PAIR SPECTROMETER VERTICAL GLUING SLIDER	
FINISH MACHINED SURFACES DEBURR & BREAK ALL SHARP EDGES		DRAWN C L HUTTON	11JAN13	SIZE C	DWG. NO. D00000-15-00-2043
DO NOT SCALE DRAWING		CHECKED		SCALE 2/1	USED ON ASSY NO. D00000-15-00-1011 SHEET 1 OF 1
		APPROVED			REV. -

4

3

2

1

4



3

2

1

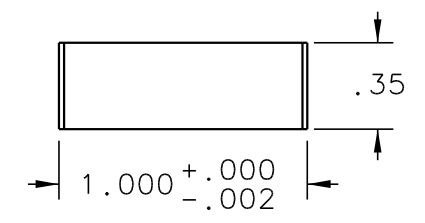
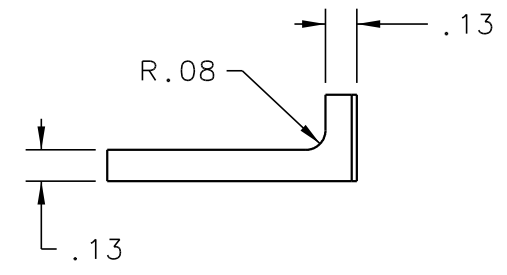
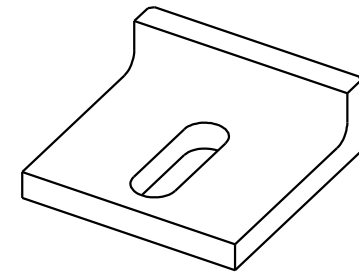
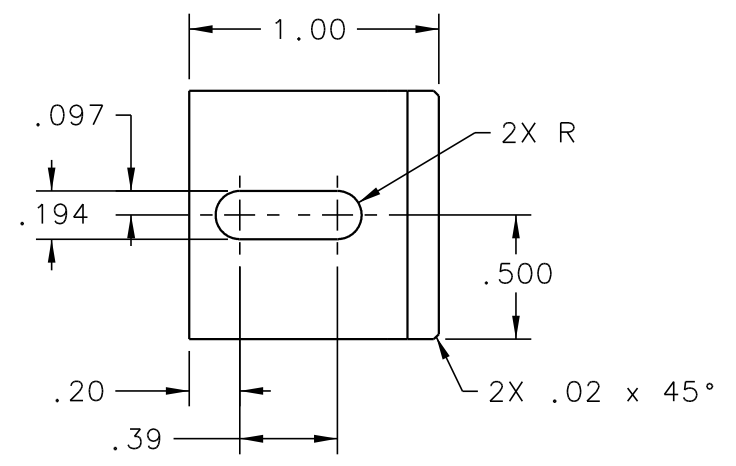
REVISION HISTORY				
ZONE	REV	DESCRIPTION	DATE	APPROVED

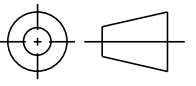

DOCUMENT CONTROL STAMP	DIM & TOL PER ASME Y14.5 . UNLESS OTHERWISE SPECIFIED DIMENSIONS ARE IN INCHES TOLERANCES ARE: FRACTIONS DECIMAL ANGLES ± N/A X ± .1 ± .50° .XX ± .01 .XXX ± .005	TRACKING NO. N/A		United States Department of Energy  Thomas Jefferson National Accelerator Facility Newport News Virginia
		APPROVALS	DATE	
MATERIAL DELTRIN	THIRD ANGLE PROJECTION	DRAWN C L HUTTON	11JAN13	SIZE DWG. NO. C D00000-15-00-2044
FINISH MACHINED SURFACES 125  UNLESS OTHERWISE NOTED DEBURR & BREAK ALL SHARP EDGES		CHECKED		
DO NOT SCALE DRAWING		APPROVED		SCALE 2/1 USED ON ASSY NO. D00000-15-00-1011 SHEET 1 OF 1

4

3

2

1

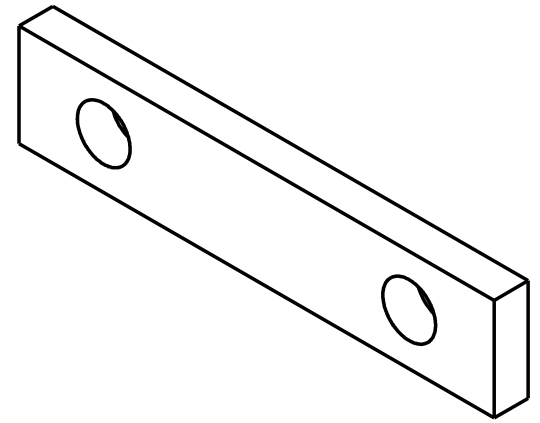
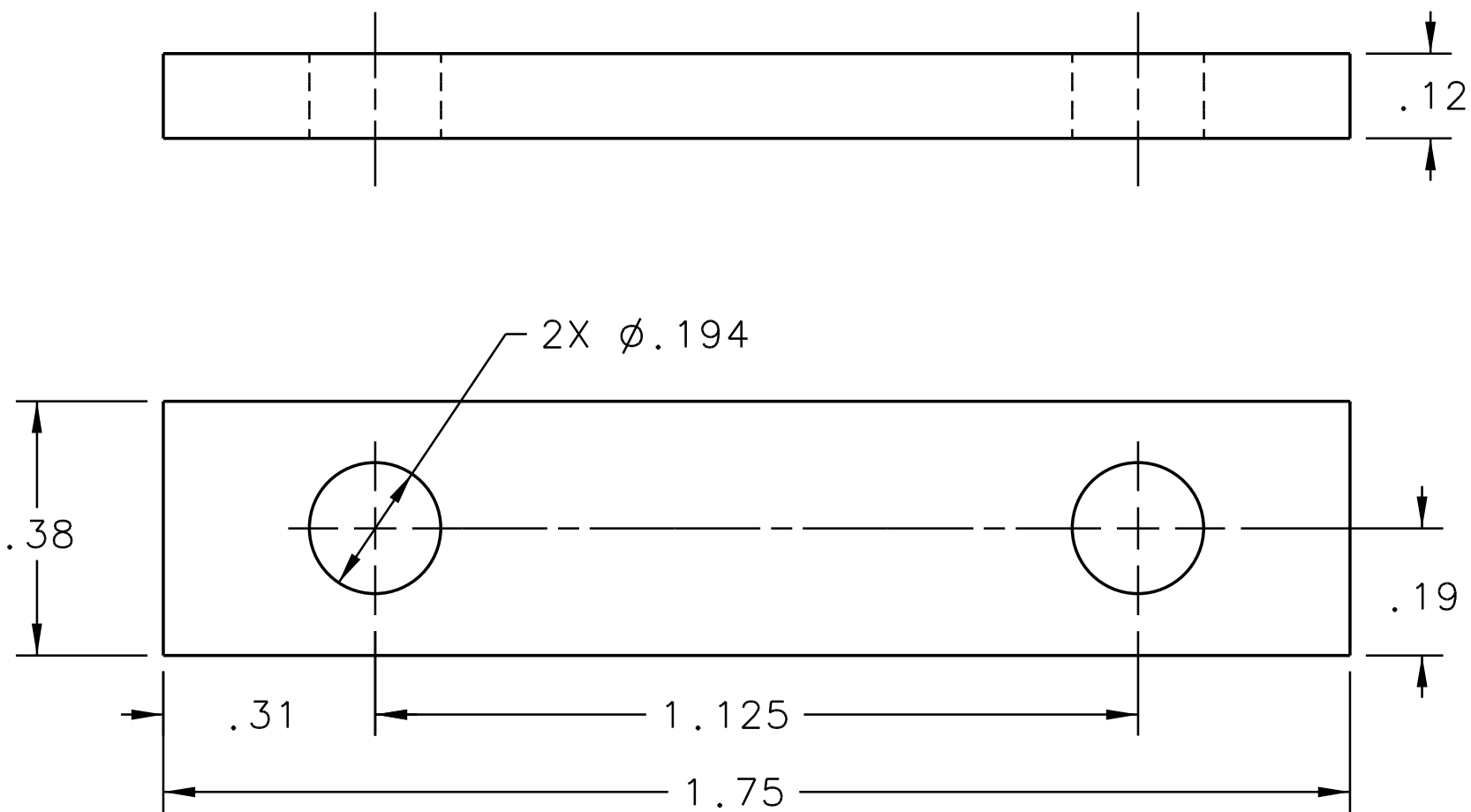

REVISION HISTORY			
REV	DESCRIPTION	DATE	APPROVED

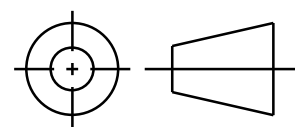

DOCUMENT CONTROL STAMP		DIM & TOL PER ASME Y14.5, UNLESS OTHERWISE SPECIFIED DIMENSIONS ARE IN INCHES TOLERANCES ARE:		TRACKING NO. N/A		United States Department of Energy		 Newport News Virginia	
MATERIAL DELFIN		FRACTIONS DECIMAL ANGLES ±N/A .X ±.1 ±.50° .XX ±.01 .XXX ±.005		APPROVALS		DATE		HALL D - GLUOX SPECTROMETER PAIR SPECTROMETER WLS STRAP	
FINISH MACHINED SURFACES 125 UNLESS OTHERWISE NOTED DEBURR & BREAK ALL SHARP EDGES		THIRD ANGLE PROJECTION		DRAWN C L HUTTON		12JAN13		SIZE DWG. NO. B D00000-15-00-2045	
DO NOT SCALE DRAWING				CHECKED				SCALE 4/1 USED ON ASSY NO. D00000-15-00-1011 SHEET 1 OF 1	
				APPROVED				REV. -	
				APPROVED					

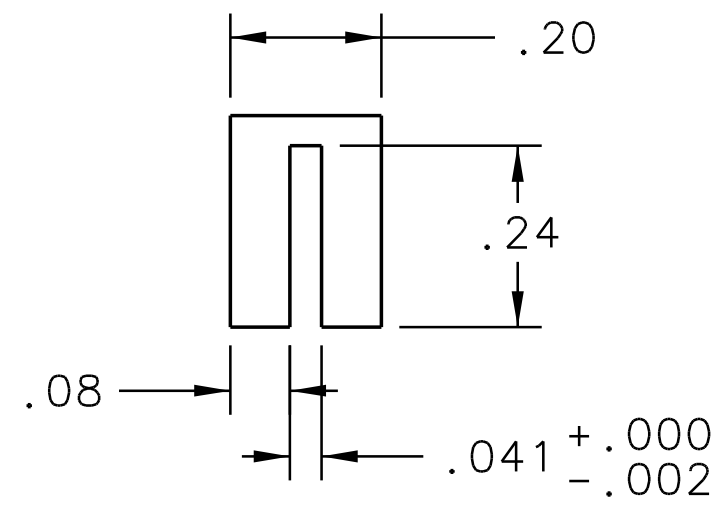
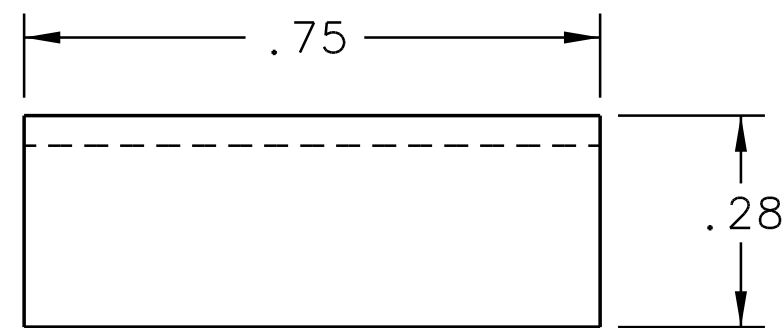
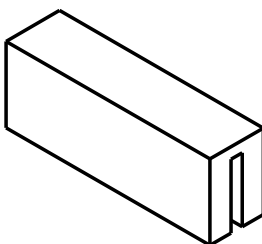
REVISION HISTORY			
REV	DESCRIPTION	DATE	APPROVED

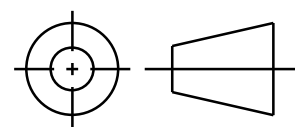

DOCUMENT CONTROL STAMP	DIM & TOL PER ASME Y14.5. UNLESS OTHERWISE SPECIFIED DIMENSIONS ARE IN INCHES TOLERANCES ARE: FRACTIONS DECIMAL ANGLES \pm N/A .X \pm .1 \pm .50° .XX \pm .01 .XXX \pm .005	TRACKING NO. N/A		United States Department of Energy  Thomas Jefferson National Accelerator Facility Newport News Virginia
		APPROVALS	DATE	
MATERIAL DELFIN	THIRD ANGLE PROJECTION	DRAWN C L HUTTON	15JAN13	SIZE DWG. NO. B D00000-15-00-2046 REV. -
FINISH MACHINED SURFACES 125  UNLESS OTHERWISE NOTED DEBURR & BREAK ALL SHARP EDGES		CHECKED		
DO NOT SCALE DRAWING		APPROVED		
		APPROVED		